

SECTION 4 CHARTS AND DIAGRAMS

NOTES OF SCHEMATIC DIAGRAM

Safety precautions

The Components identified by the symbol  are critical for safety. For continued safety, replace safety critical components only with manufacturer's recommended parts.

1. Units of components on the schematic diagram

Unless otherwise specified.

- 1) All resistance values are in ohm, 1/6 W, 1/8 W (refer to parts list).
Chip resistors are 1/16 W.
K: K Ω (1000 Ω), M: M Ω (1000K Ω)
- 2) All capacitance values are in μ F, (P: PF).
- 3) All inductance values are in μ H, (m: mH).
- 4) All diodes are 1SS133, MA165 or 1N4148M (refer to parts list).

2. Indications of control voltage

AUX : Active at high

AUX or AUX(L) : Active at low

3. Interpreting Connector indications

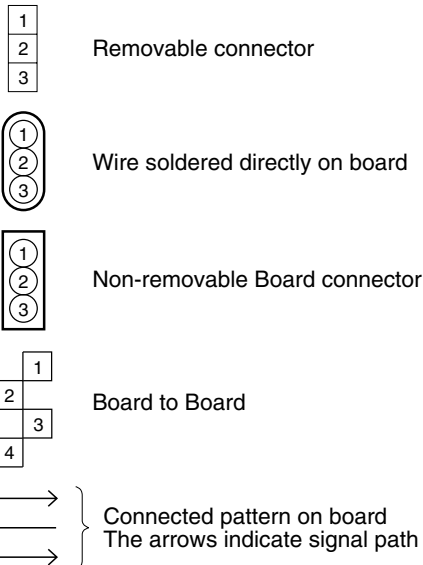

4. Voltage measurement

- 1) Video circuits
REC : Colour bar signal in SP mode, normal VHS mode
PB : Alignment tape, colour bar SP mode, normal VHS mode
— : Unmeasurable or unnecessary to measure
- 2) Audio circuits
REC : 1KHz, -8 dBs sine wave signal in SP mode, Normal VHS mode
PB : REC then playback it
- 3) Movie Camera circuits
Measured using a correctly illuminated gray scale or colour bar test charts in the E-E mode

- 4) Indication on schematic diagram
Voltage Indications for REC and PB mode on the schematic diagram are as shown below.

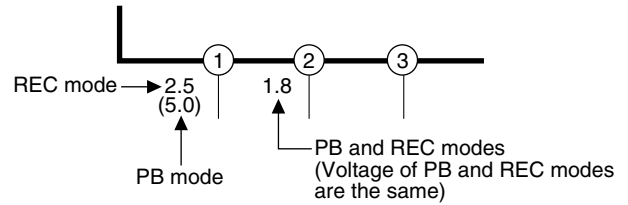

Note: If the voltages are not indicated on the schematic diagram, refer to the voltage charts.

5. Waveform measurement

- 1) Video circuits
REC : Colour bar signal in SP mode, normal VHS mode
PB : Alignment tape, colour bar SP mode, normal VHS mode
- 2) Audio circuits
REC : 1KHz, -8 dBs sine wave signal in SP mode, normal VHS mode
PB : REC then playback it
- 3) Movie Camera circuits
Measured using a correctly illuminated gray scale or colour bar test charts in the E-E mode
- 4) Indication on schematic diagram
Waveform indications on the schematic diagram are as shown below.

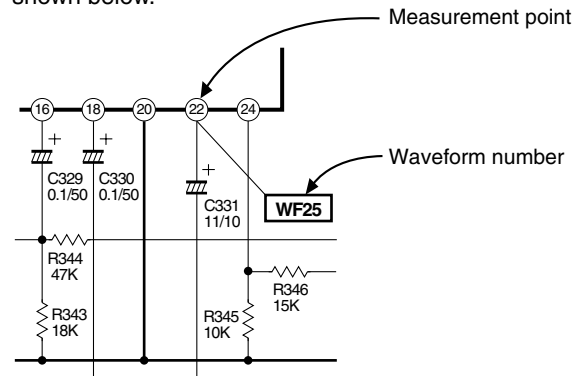

5) Waveform indications

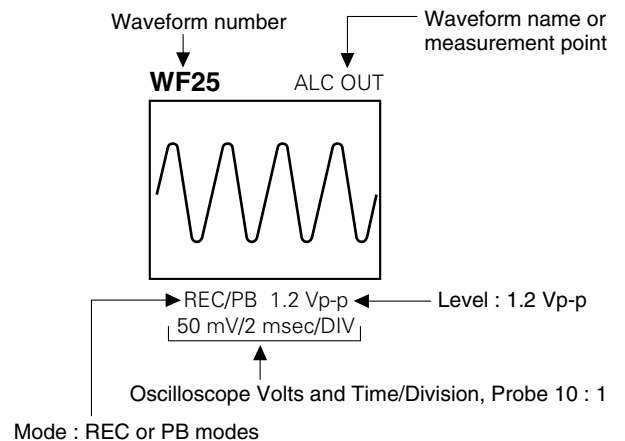

6. Signal path Symbols

The arrows indicate the signal path as follows.

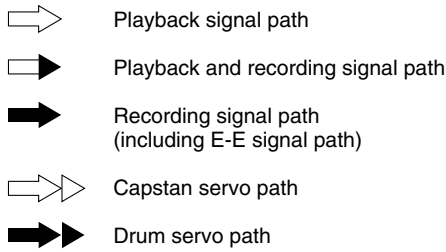

(Example)

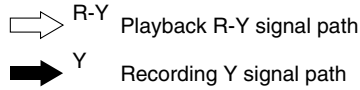

7. Indication of the parts for adjustments

The parts for the adjustments are surrounded with the circle as shown below.

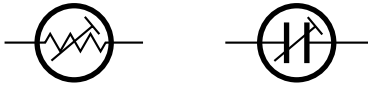

8. Indication of the parts not mounted on the circuit board

“OPEN” is indicated by the parts not mounted on the circuit board.



CIRCUIT BOARD NOTES

1. Foil and Component sides

- 1) Foil side (B side) :
Parts on the foil side seen from foil face (pattern face) are indicated.
- 2) Component side (A side) :
Parts on the component side seen from component face (parts face) indicated.

2. Parts location guides

Parts location are indicated by guide scale on the circuit board.

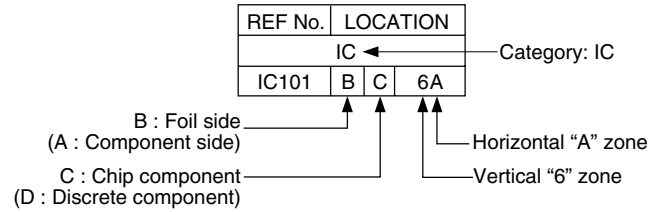

Note:

For general information in service manual, please refer to the Service Manual of GENERAL INFORMATION Edition 4 No. 82054D (January 1994).

4.1 BOARD INTERCONNECTIONS

NOTE) *: The number of patch cords are indicated by interconnected.

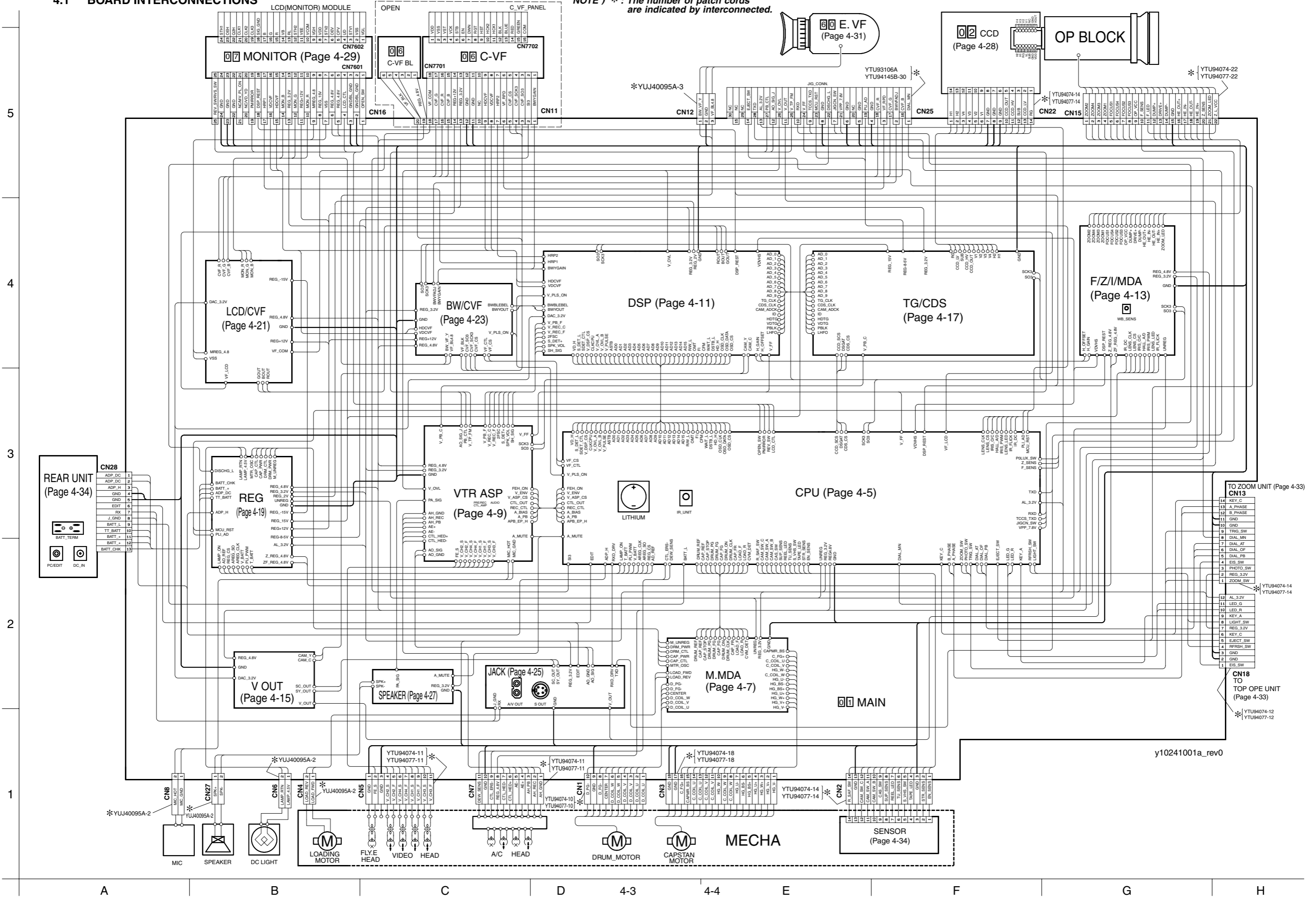

5

4

3

2

1

A

B

C

D

4-3

4-4

E

F

G

H

y10241001a_rev0

4.2 CPU SCHEMATIC DIAGRAM

NOTES : ● For the destination of each signal and further line connections that are cut off from this diagram, refer to "4.1 BOARD INTERCONNECTIONS".
● When ordering parts, be sure to order according to the Part Number indicated in the Parts List.

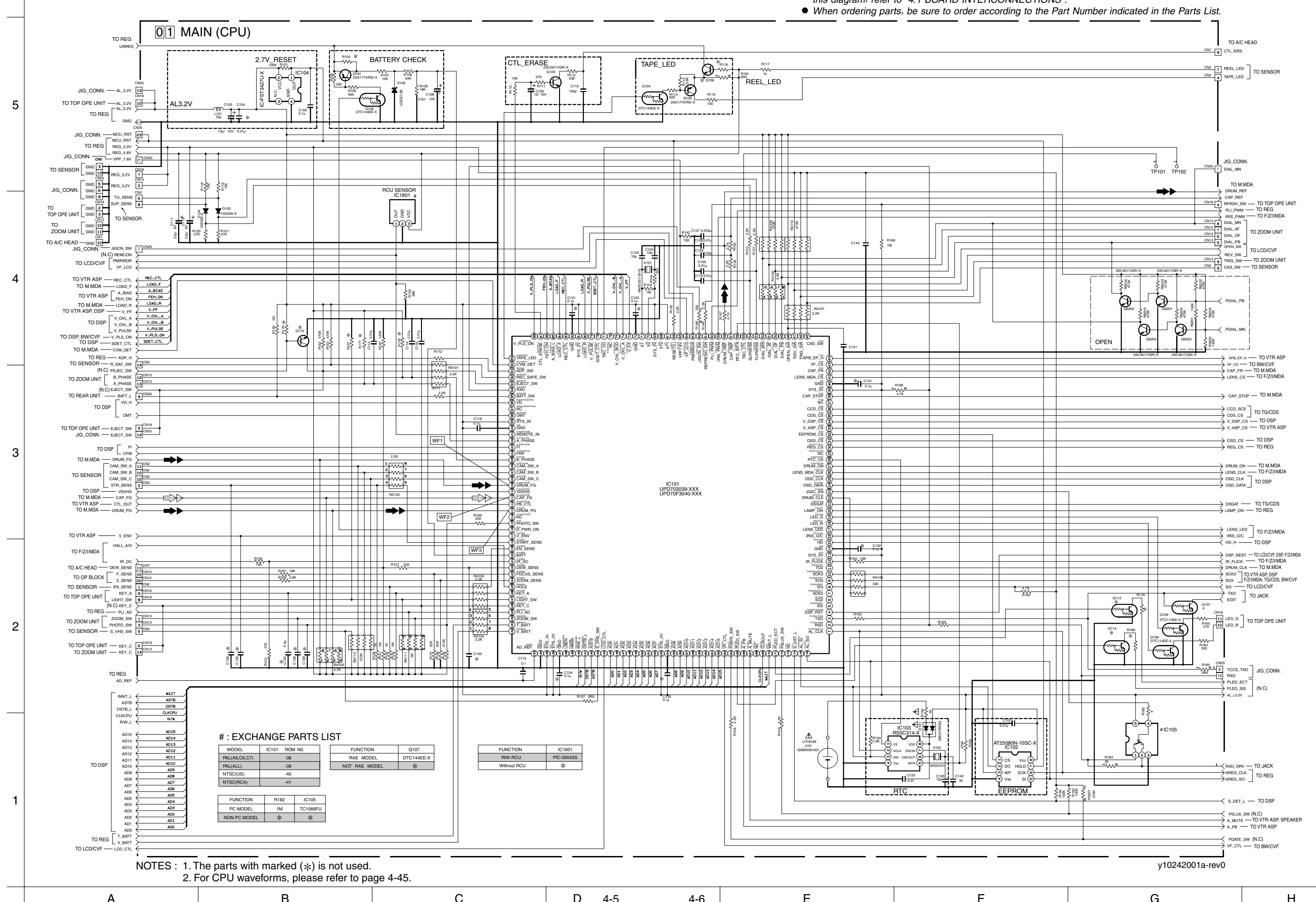

: EXCHANGE PARTS LIST

MODEL	IC101	ROM NO.	FUNCTION	Q107
PAL(A6,C6,C7)	-38		RAE MODEL	DTC144EE-X
PAL(ALL)	-39		NOT RAE MODEL	*
NTSC(LUS)	-40			
NTSC(RCA)	-41			

FUNCTION	R182	IC105
PC MODEL	1M	TC1566FU
NON PC MODEL	*	*

FUNCTION	IC1801
With RCU	PIC-26043S
Without RCU	*

NOTES : 1. The parts with marked (*) is not used.
2. For CPU waveforms, please refer to page 4-45.

4.3 M.MDA SCHEMATIC DIAGRAM

NOTES : ● For the destination of each signal and further line connections that are cut off from this diagram, refer to "4.1 BOARD INTERCONNECTIONS".
 ● When ordering parts, be sure to order according to the Part Number indicated in the Parts List.

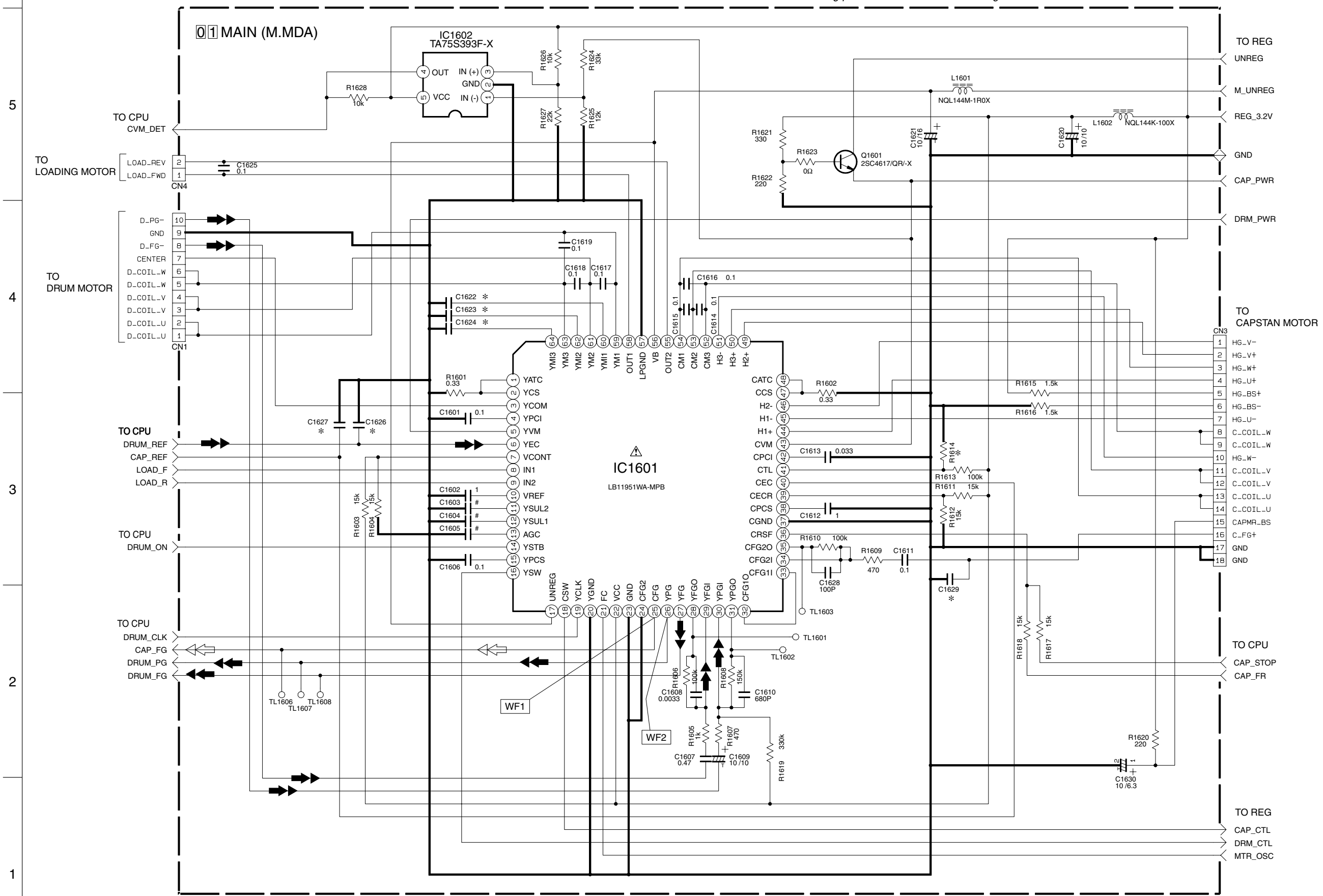

NOTES : 1. The parts with marked (*) is not used.
 2. For M.MDA waveforms, please refer to page 4-45.

: EXCHANGE PARTS LIST

	NTSC	PAL
C1603	0.0047	0.01
C1604	0.0047	0.01
C1605	0.033	0.01

y20156001a_rev0

4.4 VTR ASP SCHEMATIC DIAGRAM

NOTES : ● For the destination of each signal and further line connections that are cut off from this diagram, refer to "4.1 BOARD INTERCONNECTIONS".
 ● When ordering parts, be sure to order according to the Part Number indicated in the Parts List.

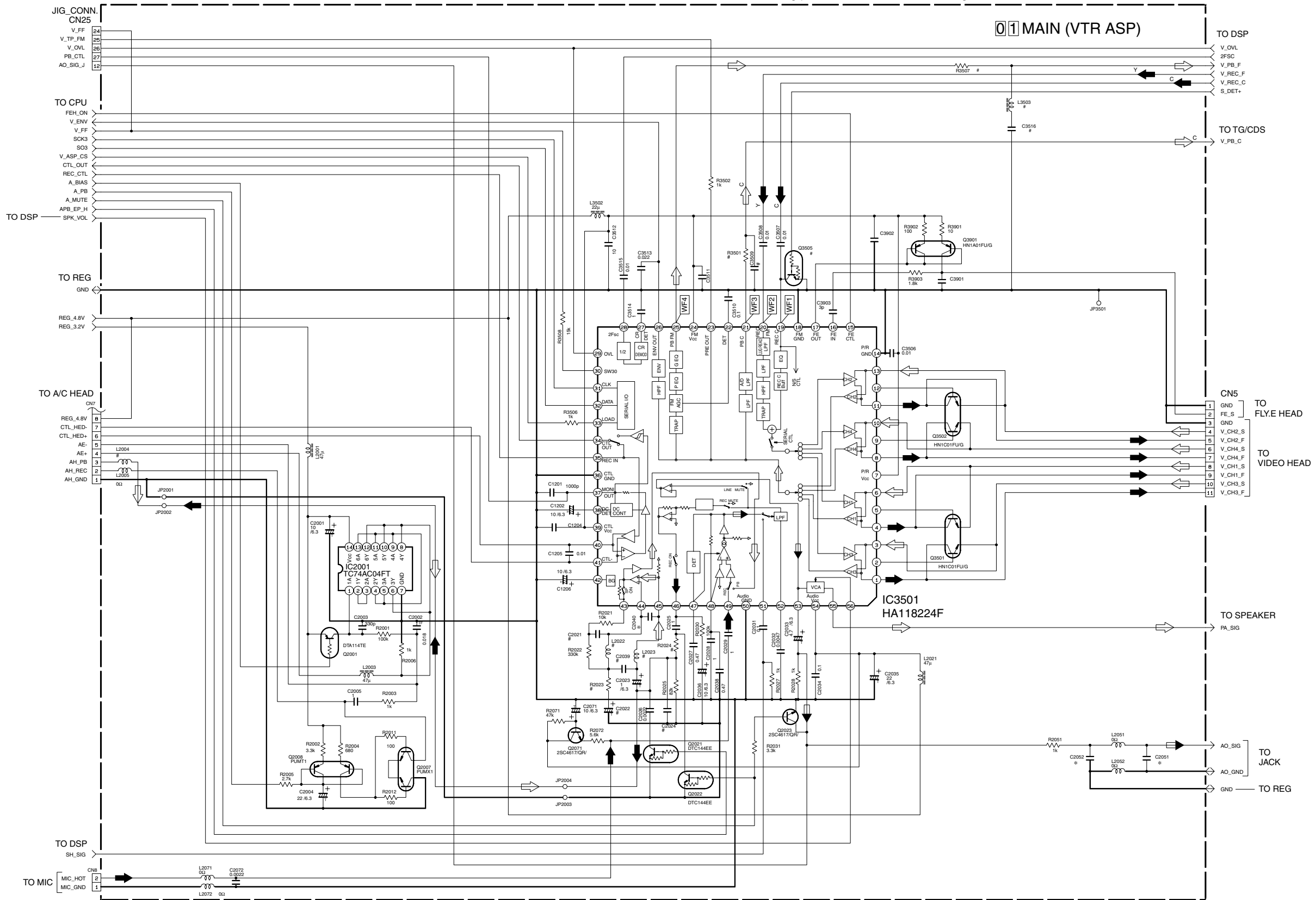

NOTES : 1. The parts with marked (*) is not used.
 2. For VTR ASP waveforms, please refer to page 4-45.

: EXCHANGE PARTS LIST

		[VIDEO]		[AUDIO]	
	VHS MODEL	NTSC	PAL	NTSC	PAL
Q3505	*	DTC144 EE			
R3507		0	100		
L3503	*		5.6		
C3516	*		10p		
R3501		0	220		
C3509	*		220p		
R2023		150	82		
R2024		13k	18k		
C2021		0.0068	0.01		
C2022		10 μ/6.3	15 μ/6.3		
C2024		0.0012	0.001		
L2004		0 Ω	NQR0403-003X		
L2022		0 Ω	NQR0403-003X		
L2023		0 Ω	NQR0406-003X		
C2039	*		33 p		

5
4
3
2
1

A B C D 4-9 4-10 E F G H

4.5 DSP SCHEMATIC DIAGRAM

NOTES : ● For the destination of each signal and further line connections that are cut off from this diagram, refer to "4.1 BOARD INTERCONNECTIONS".
 ● When ordering parts, be sure to order according to the Part Number indicated in the Parts List.

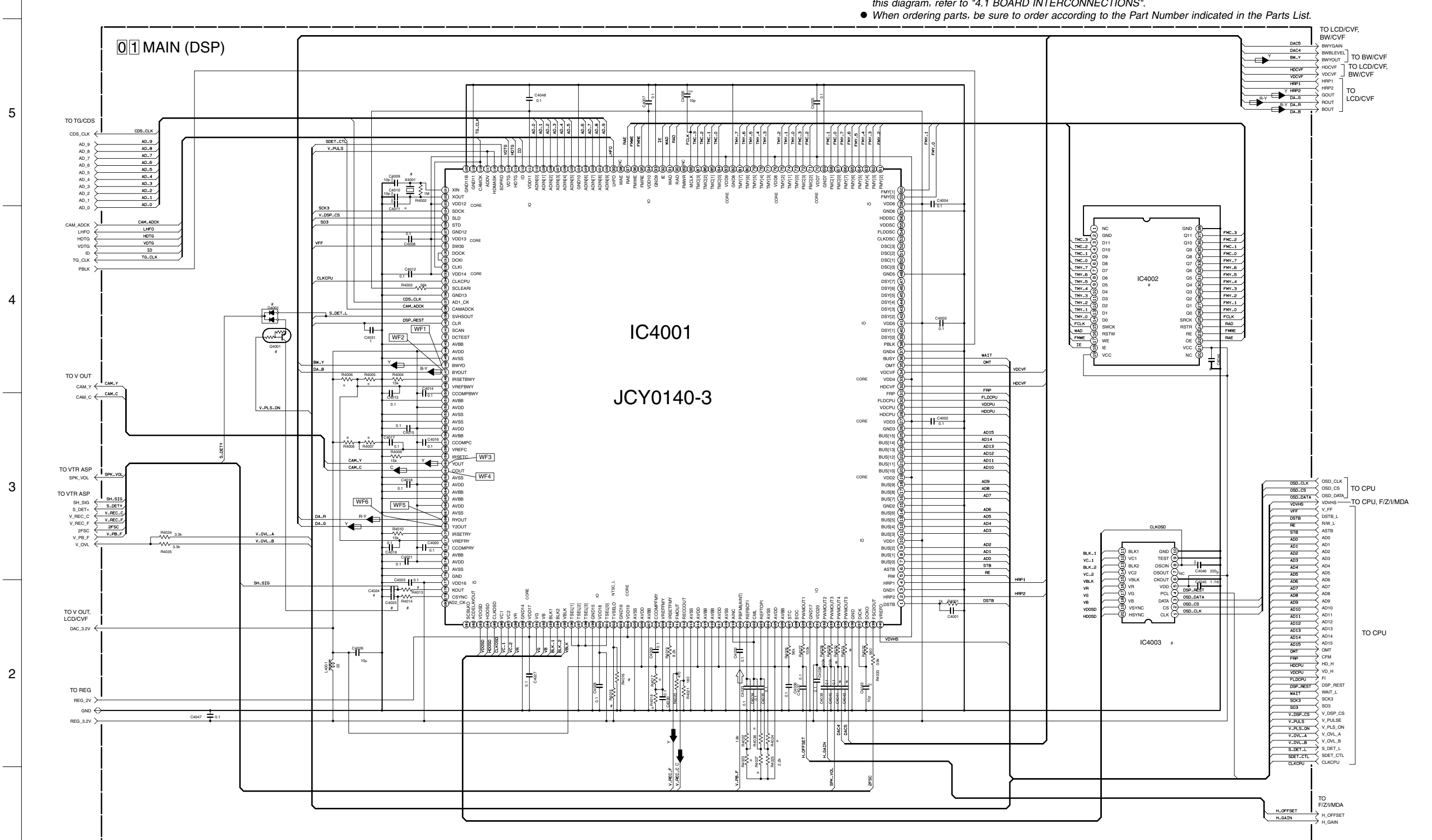

NOTES : 1. The parts with marked (*) is not used.
 2. For DSP waveforms, please refer to page 4-45.

: EXCHANGE PARTS LIST

	X4001	R4015	R4016						
NTSC	QAX0709-001	*	0						
PAL	QAX0708-001	0	*						

	R4014	C4025	Q4001	D4001				
VHS MODEL	*	*	*	*				
SVHS MODEL	10k	0.1	DTC144E-X	DAN222-X				

MEMORY MODEL	IC4002	Z4C2973-32-X	C4044	1 μ					
NON MEMORY MODEL	*	*	*	*					

NON PB SNAP SHOT	R4013	C4024	*	*					
PB SNAP SHOT	1k	0.1							

JVC C-VF MODEL	R4030	C4041	R4031	C4042	IC4003				
JVC OTHER MODEL	*	*	*	*	μ PD6467GR-512-X				
PANASONIC MODEL	1k	1 μ	1k	1 μ	μ PD6467GR-509-X				

y10243001a_rev0

4.6 F/Z/I/MDA SCHEMATIC DIAGRAM

NOTES : ● For the destination of each signal and further line connections that are cut off from this diagram, refer to "4.1 BOARD INTERCONNECTIONS".
 ● When ordering parts, be sure to order according to the Part Number indicated in the Parts List.

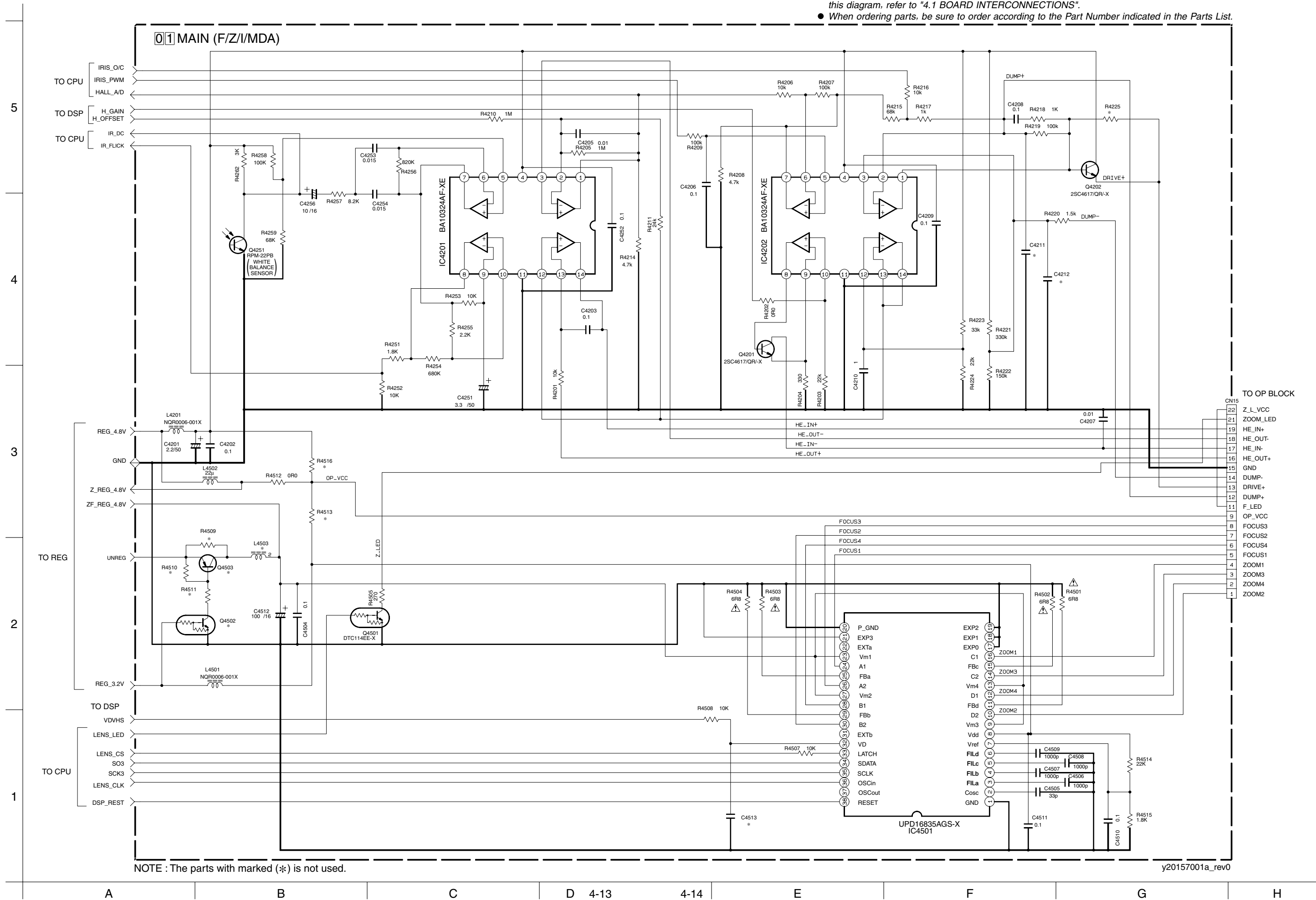

NOTE : The parts with marked (*) is not used.

y20157001a_rev0

4.7 V OUT SCHEMATIC DIAGRAM

NOTES : ● For the destination of each signal and further line connections that are cut off from this diagram, refer to "4.1 BOARD INTERCONNECTIONS".
● When ordering parts, be sure to order according to the Part Number indicated in the Parts List.

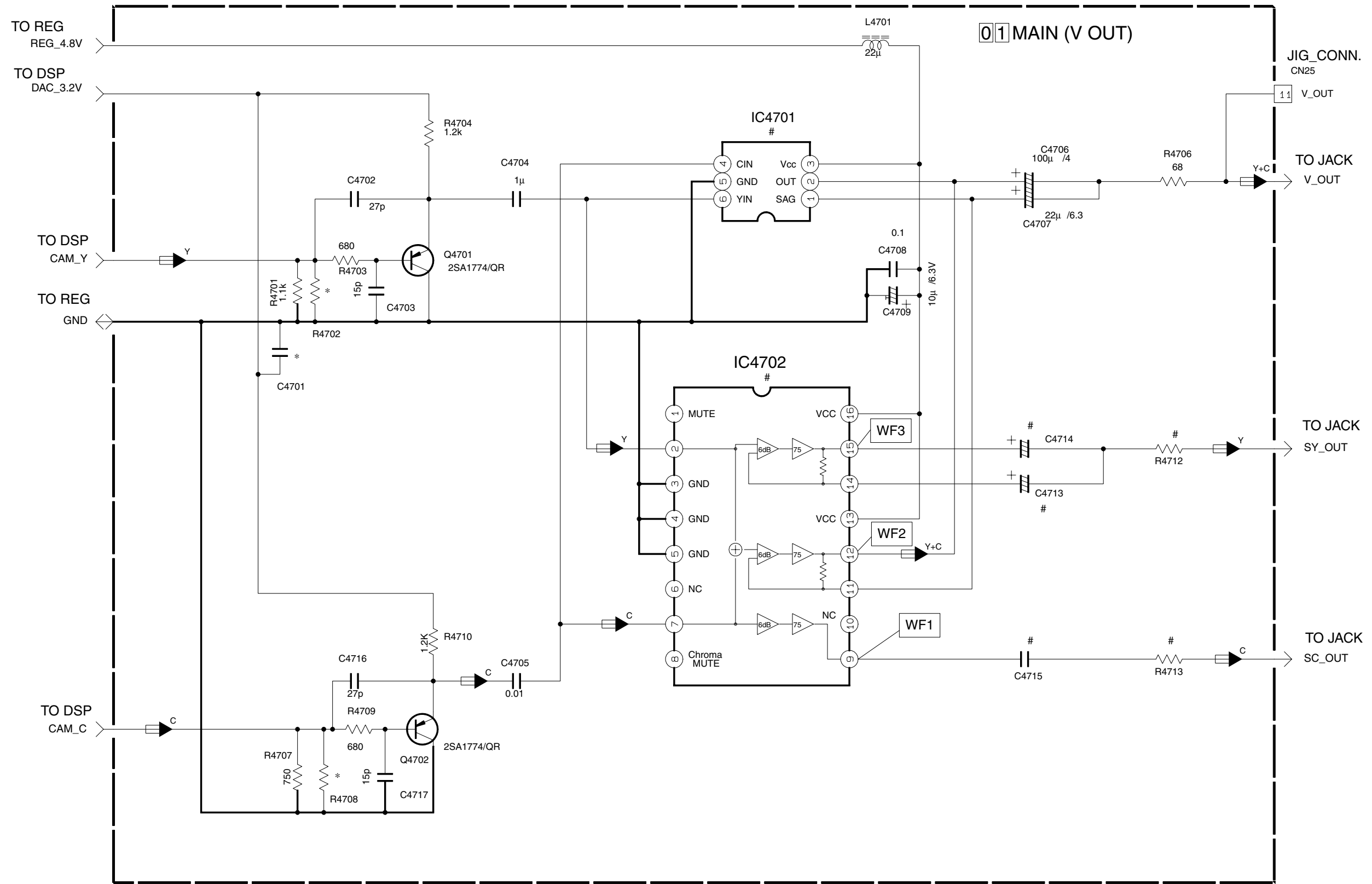

NOTES : 1. The parts with marked (*) is not used.
2. For V OUT waveforms, please refer to page 4-45.

: EXCHANGE PARTS LIST

	IC4701	IC4702	R4712	R4713	C4713	C4714	C4715
VHS MODEL	MM1512XN	*	*	*	*	*	*
SVHS MODEL	*	BA7665FS	68	68	22/6.3	100/4	0.01

y30153001a_rev0

4.8 TG/CDS SCHEMATIC DIAGRAM

NOTES : ● For the destination of each signal and further line connections that are cut off from this diagram, refer to "4.1 BOARD INTERCONNECTIONS".
● When ordering parts, be sure to order according to the Part Number indicated in the Parts List.

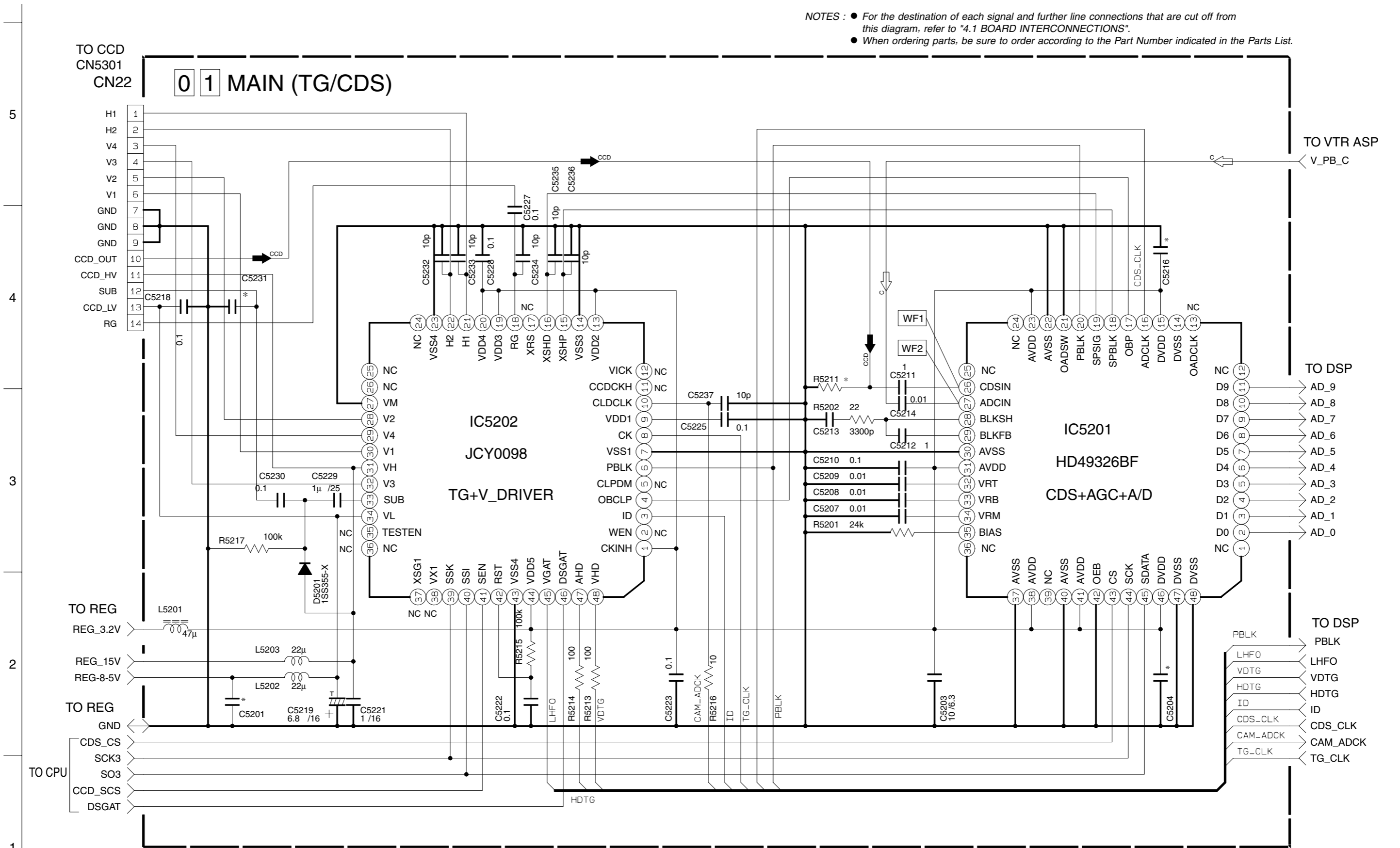

NOTES : 1. The parts with marked (*) is not used.
2. For TG/CDS waveforms, please refer to page 4-45.

y30152001a_rev0

4.9 REG SCHEMATIC DIAGRAM

NOTES : ● For the destination of each signal and further line connections that are cut off from this diagram, refer to "4.1 BOARD INTERCONNECTIONS".
 ● When ordering parts, be sure to order according to the Part Number indicated in the Parts List.

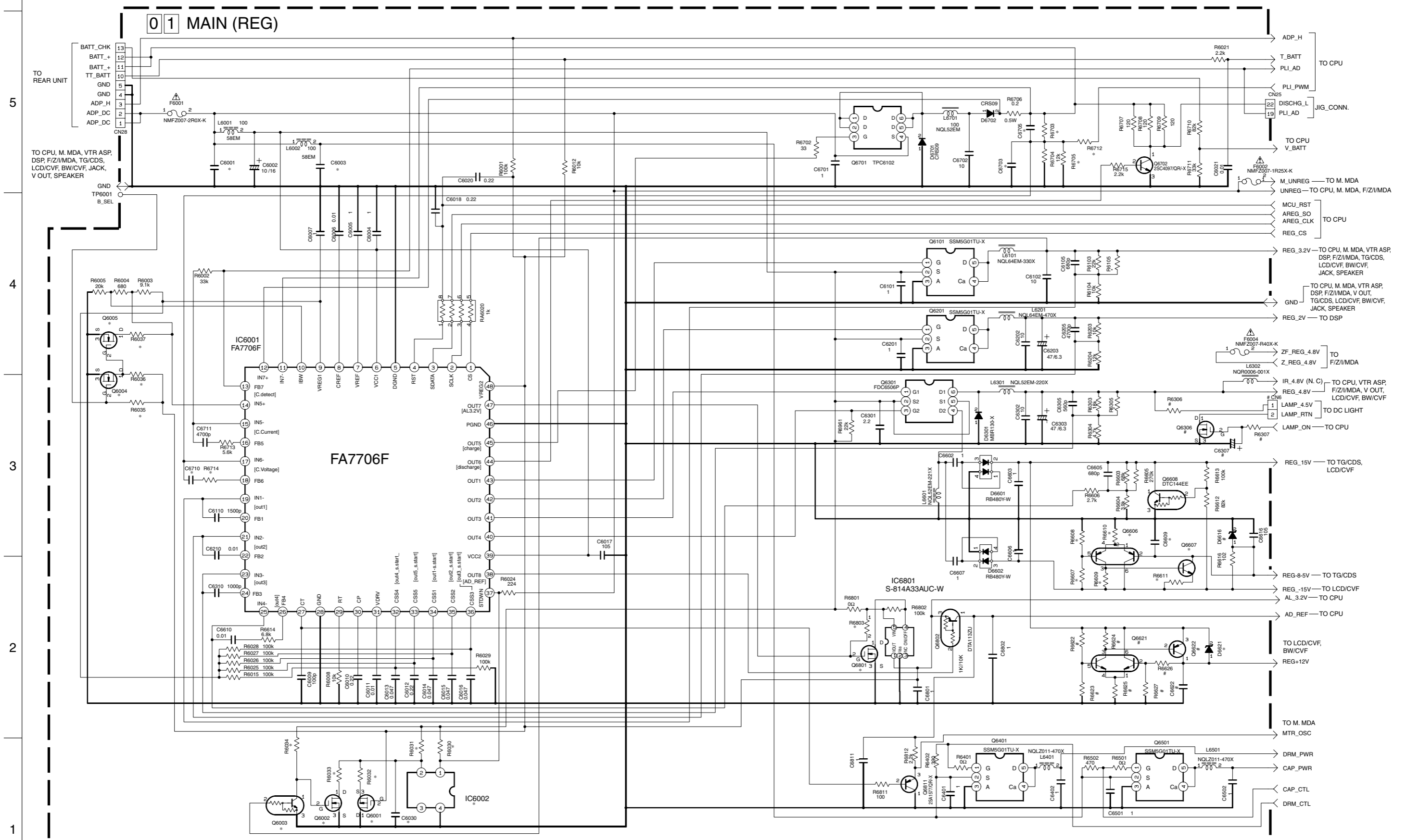

NOTE : The parts with marked (*) is not used.

: EXCHANGE PARTS LIST

	D6616
NTSC	UDZ58.2B-X
PAL	UDZ57.5B-X

	R6306	R6307	Q6306	C6307	CN6	
Light	YES	0.47	100k	SSM3K02F	10μ/16	QG1201C2-02X
Light	NO	*	*	*	*	*

	R6622	R6623	R6624	R6625	R6626	R6627	Q6621	Q6622	C6622
JVC WB VF ONLY MODEL	*	*	*	*	*	*	*	*	*
JVC WB VF and 2.SLCD MODEL	*	*	*	*	*	*	*	*	*
JVC OTHER MODEL	100k	47k	27k	8.2k	27k	18k	HN1C01FU	2SA1577	1μ

y20159001a_rev0

A

B

C

D

4-19

4-20

E

F

G

H

4.10 LCD/CVF SCHEMATIC DIAGRAM

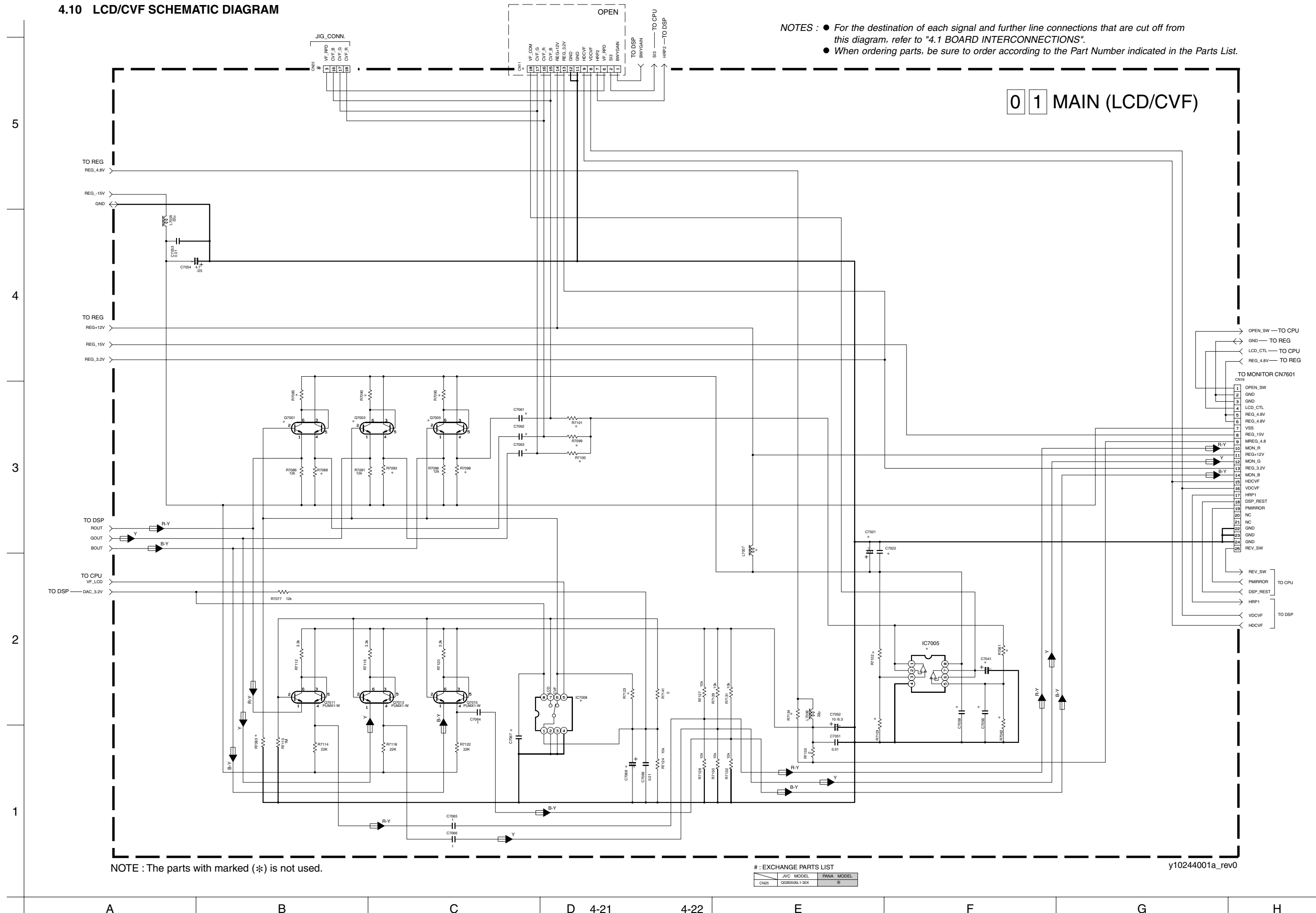

NOTES : ● For the destination of each signal and further line connections that are cut off from this diagram, refer to "4.1 BOARD INTERCONNECTIONS".
 ● When ordering parts, be sure to order according to the Part Number indicated in the Parts List.

0 1 MAIN (LCD/CVF)

NOTE : The parts with marked (*) is not used.

: EXCHANGE PARTS LIST

	JVC MODEL	PANA MODEL
CN25	OG8050AL1-30X	*

y10244001a_rev0

4.11 BW/CVF SCHEMATIC DIAGRAM

NOTES : ● For the destination of each signal and further line connections that are cut off from this diagram, refer to "4.1 BOARD INTERCONNECTIONS".
● When ordering parts, be sure to order according to the Part Number indicated in the Parts List.

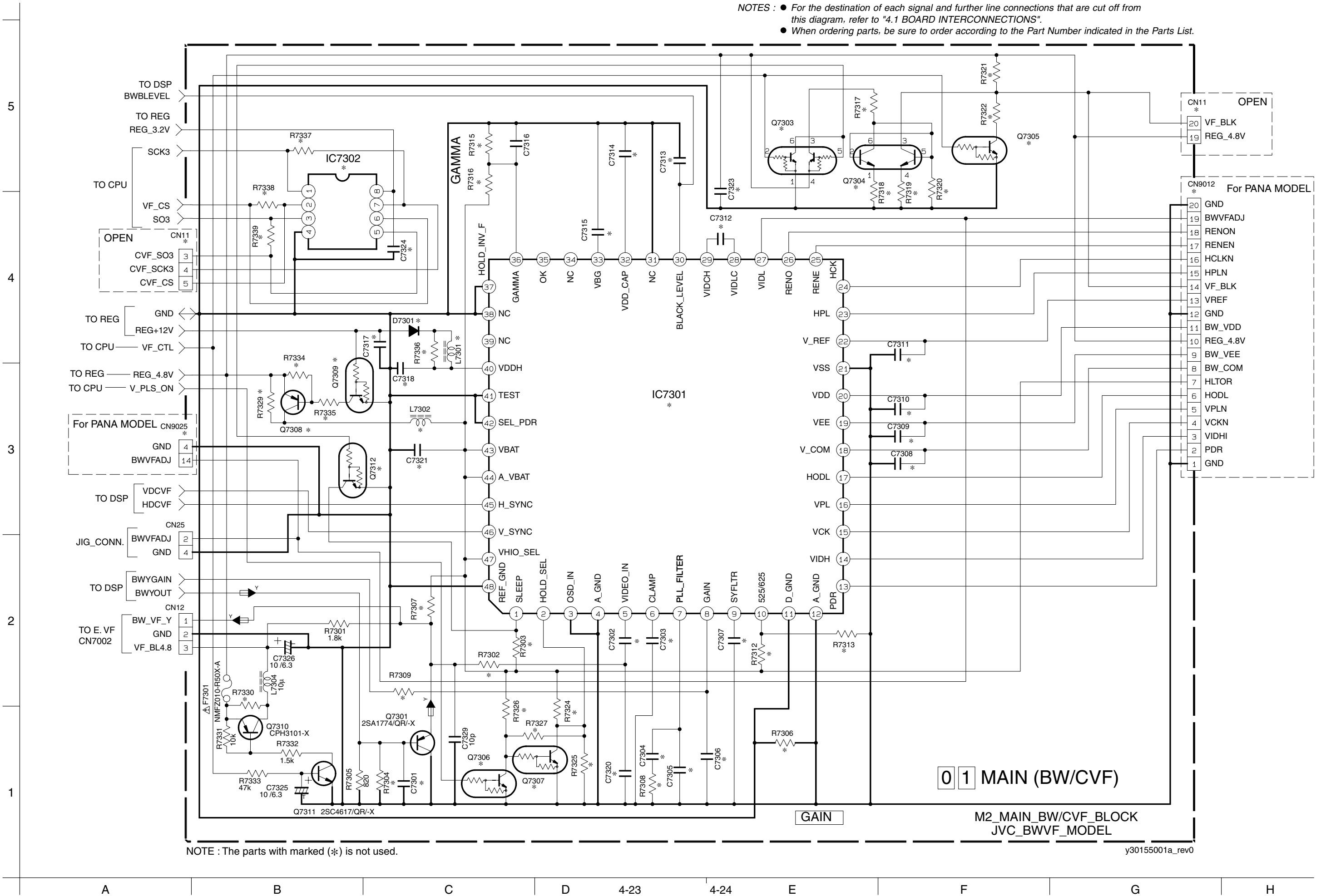

NOTE : The parts with marked (*) is not used.

y30155001a_rev0

4.12 JACK SCHEMATIC DIAGRAM

NOTES : ● For the destination of each signal and further line connections that are cut off from this diagram, refer to "4.1 BOARD INTERCONNECTIONS".
● When ordering parts, be sure to order according to the Part Number indicated in the Parts List.

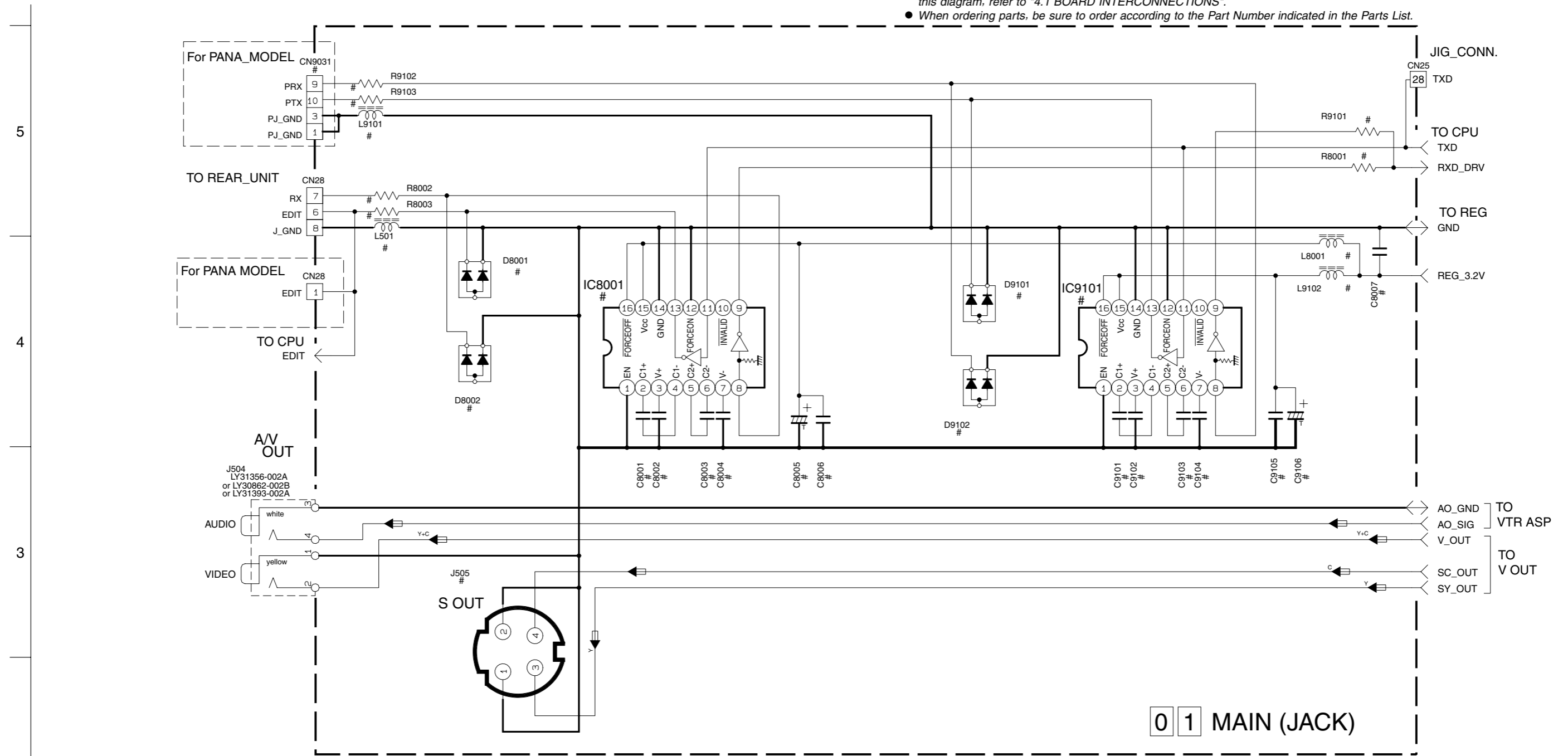

0 1 MAIN (JACK)

Exchange Parts List

NOTE : The parts with marked (*) is not used.

y30154001a_rev0

	JVC PC model	JVC NON PC model PANA model		PANA PC model	JVC model PANA NON PC model		S model	NON S model		JVC model with EDIT/DIGITAL terminal	JVC model without EDIT/DIGITAL terminal	PANA model
	IC8001	MAX3221CAE-X	*	IC9101	MAX3221CAE-X	*	J505	QND0068-001 or QND0078-001 or QND0087-001	*	L501	0Ω	*
	R8001	330	*	R9101	330	*				L9101	*	*
	R8002	0	*	R9102	0	*				CN9031	*	*
	R8003	0	*	R9103	0	*						
	C8001	0.1	*	C9101	0.1	*						
	C8002	0.1	*	C9102	0.1	*						
	C8003	0.1	*	C9103	0.1	*						
	C8004	0.1	*	C9104	0.1	*						
	C8005	10/6.3	*	C9105	10/6.3	*						
	C8006	0.1	*	C9106	0.1	*						
	C8007	*	*	D9101	EMZ6.8N-X	*						
	D8001	EMZ6.8N-X	*	D9102	EMZ6.8N-X	*						
	D8002	EMZ6.8N-X	*	L9102	22 μ	*						
	L8001	22 μ	*									

4.13 SPEAKER SCHEMATIC DIAGRAM

- NOTES :
- For the destination of each signal and further line connections that are cut off from this diagram, refer to "4.1 BOARD INTERCONNECTIONS".
 - When ordering parts, be sure to order according to the Part Number indicated in the Parts List.

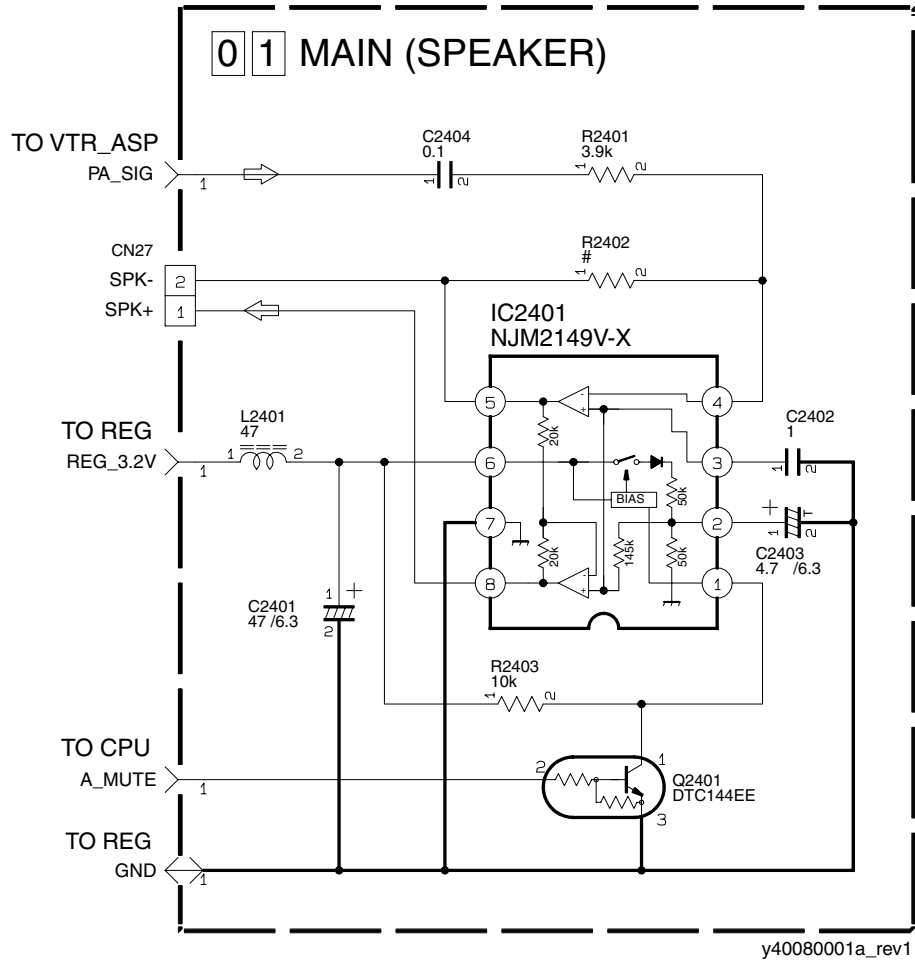

: EXCHANGE PARTS LIST

	JVC	PANA/RCA
R2402	3.3k	2.2k

4.14 CCD SCHEMATIC DIAGRAM

- NOTES :
- For the destination of each signal and further line connections that are cut off from this diagram, refer to "4.1 BOARD INTERCONNECTIONS".
 - When ordering parts, be sure to order according to the Part Number indicated in the Parts List.

- IC5301 is incorporated in the CCD base assembly. When IC5301 needs replacement, replace the CCD base assembly in whole because it cannot be replaced alone.

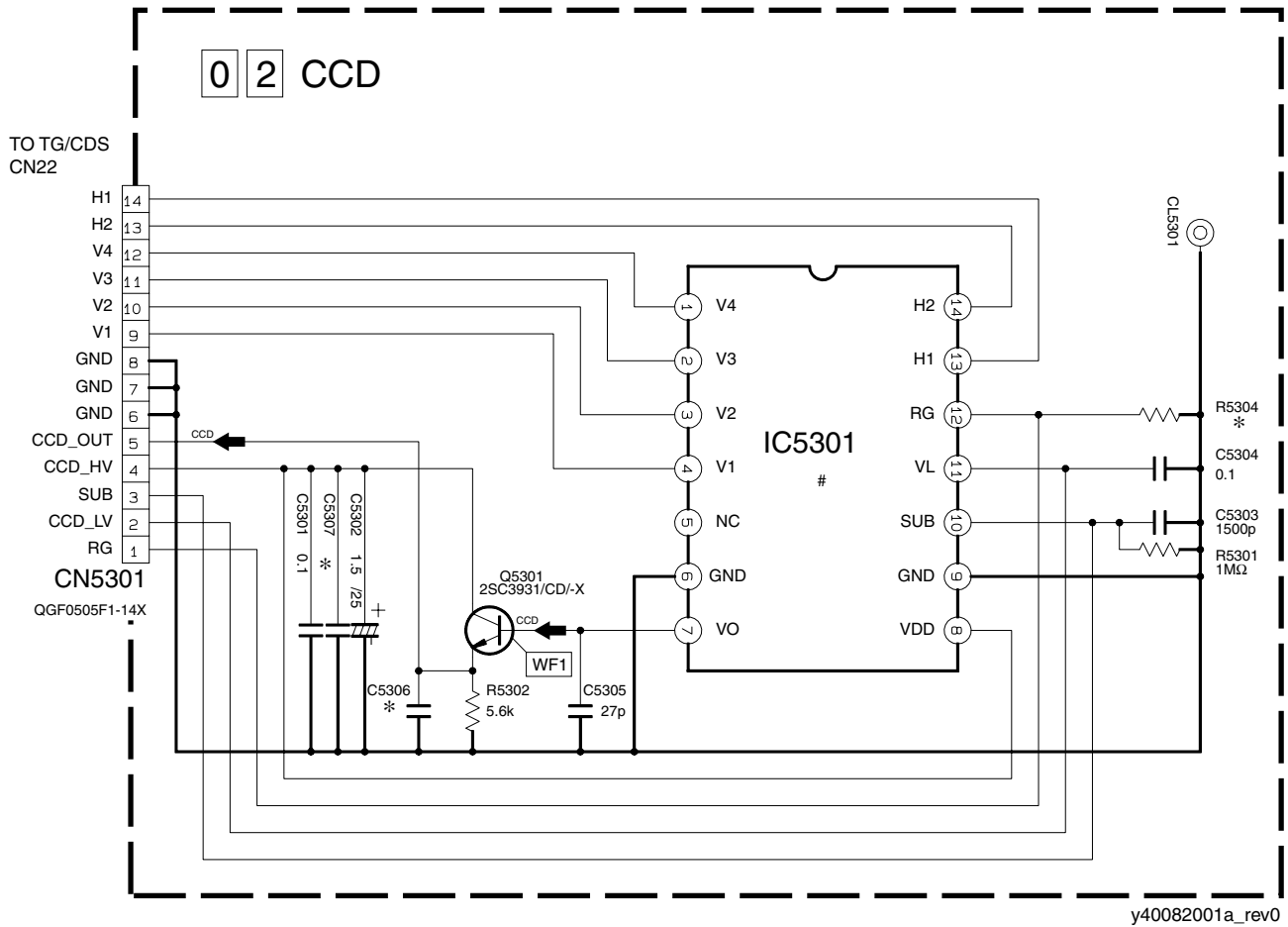

- NOTES :
1. The parts with marked (*) is not used.
 2. For CCD waveform, please refer to page 4-45.

MODEL	IC5301	CCD_HV	CCD_LV
NTSC_L	MN39117FT	15V	-8V
PAL_L	ICX297AKA-L	15V	-7.5V

4.15 MONITOR SCHEMATIC DIAGRAM

NOTES : ● For the destination of each signal and further line connections that are cut off from this diagram, refer to "4.1 BOARD INTERCONNECTIONS".
● When ordering parts, be sure to order according to the Part Number indicated in the Parts List.

07 MONITOR

: EXCHANGE PARTS LIST

	R7618	R7619
NTSC	*	NRSA63J-0R0X
PAL	NRSA63J-0R0X	*

	IC7603	R7642	C7627	R7602	L7603	L7604	R7637	R7640	R7641	R7645	R7607
Type_2.5	SN74AHC1G04K-X	*	NCB31EK-103X	NRVA63D-752X	*	NQL38DK-220X	NRSA63J-223X	NRSA02J-182X	NRSA02J-331X	NRSA63J-682X	NRSA63J-822X
Type_3.0	*	NRSA63J-0R0X	*	NRVA63D-432X	NQL38DK-220X	*	NRSA63J-682X	NRSA02J-122X	NRSA02J-821X	NRSA63J-123X	NRSA63J-153X
Type_3.5	*	NRSA63J-0R0X	*	NRVA63D-432X	NQL38DK-220X	*	NRSA63J-682X	NRSA02J-122X	NRSA02J-821X	NRSA63J-123X	NRSA63J-153X

	C7623	R7643	R7644	C7630	R7647	R7648	Q7607	R7649	R7650	R7646	R7622
Type_2.5	NCB31EK-682X	*	*	*	*	NRSA63J-103X	DTC144EE-X	*	NRSA63J-103X	NRSA63J-392X	*
Type_3.0	*	NRSA63J-123X	NRSA63J-123X	NCB31EK-103X	NRSA63J-0R0X	*	*	NRSA63J-333X	*	NRSA63J-222X	*
Type_3.5	*	NRSA63J-123X	NRSA63J-123X	NCB31EK-103X	*	NRSA63J-103X	DTC144EE-X	*	NRSA63J-103X	NRSA63J-222X	NRSA63J-0R0X

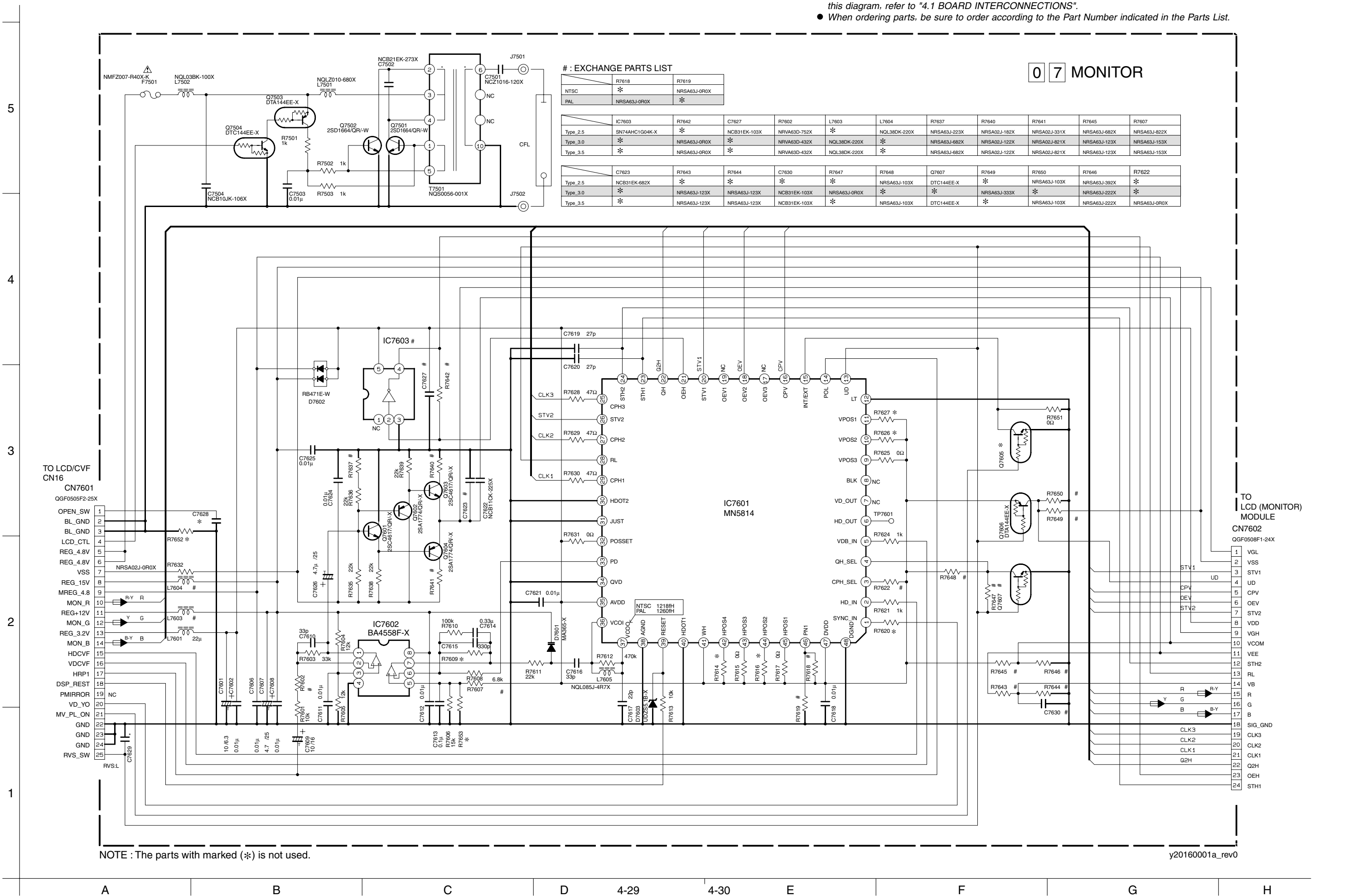

NOTE : The parts with marked (*) is not used.

y20160001a_rev0

NOTES : ● For the destination of each signal and further line connections that are cut off from this diagram, refer to "4.1 BOARD INTERCONNECTIONS".
 ● When ordering parts, be sure to order according to the Part Number indicated in the Parts List.

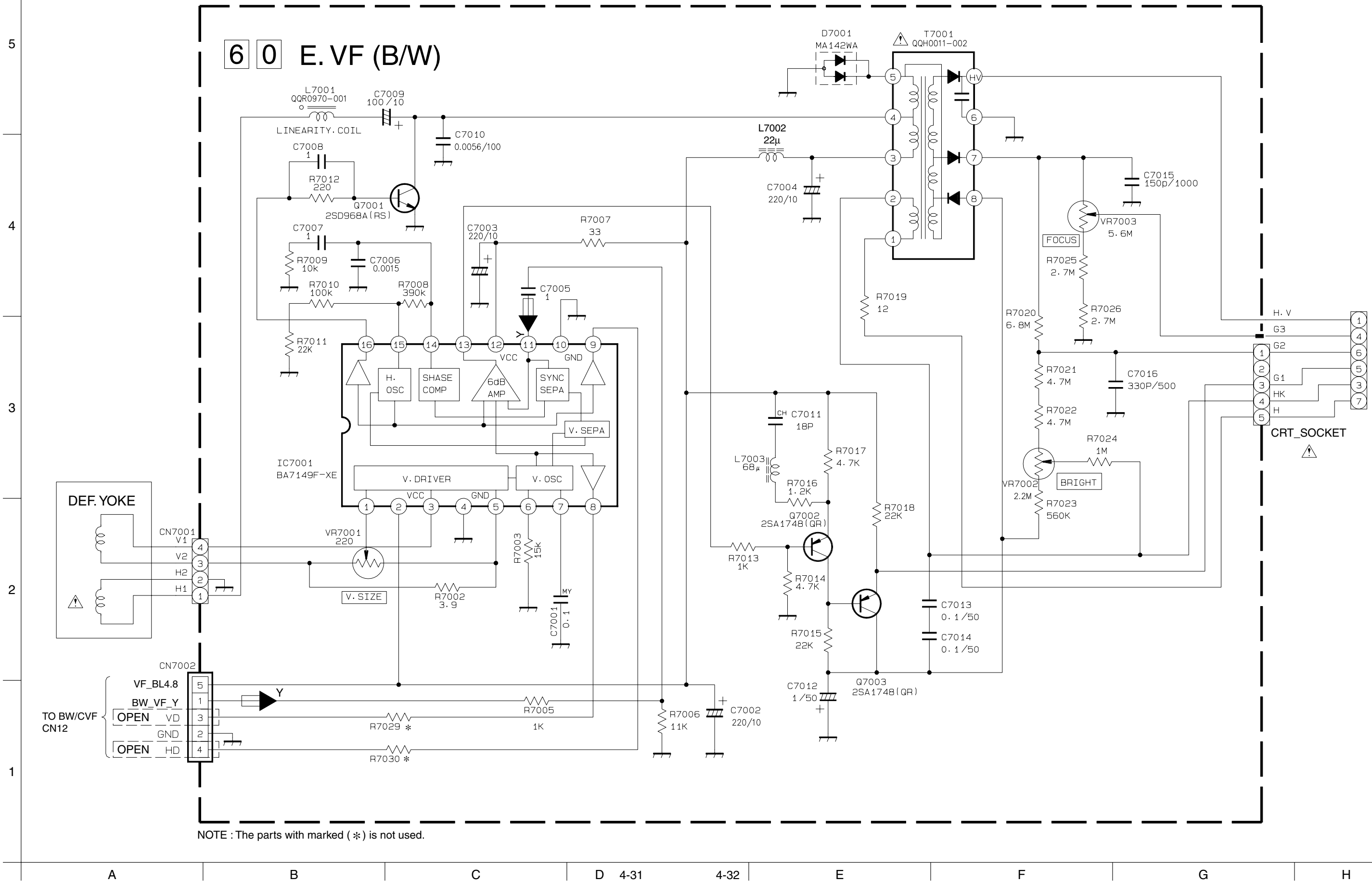

NOTE : The parts with marked (*) is not used.

4.17 TOP OPE UNIT, ZOOM UNIT, REAR UNIT AND SENSOR SCHEMATIC DIAGRAMS

-TOP OPE UNIT-

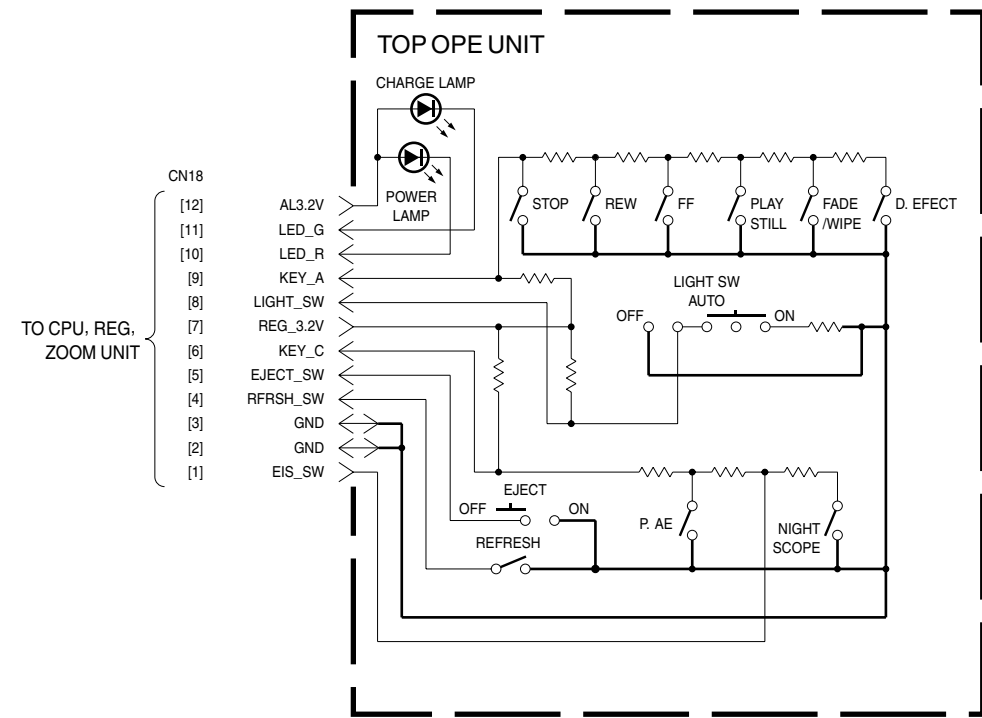

NOTES : ● For the destination of each signal and further line connections that are cut off from this diagram, refer to "4.1 BOARD INTERCONNECTIONS".
● The schematic diagram is only for reference. Avoid replacing individual parts. Replace the entire unit only.

-REAR UNIT-

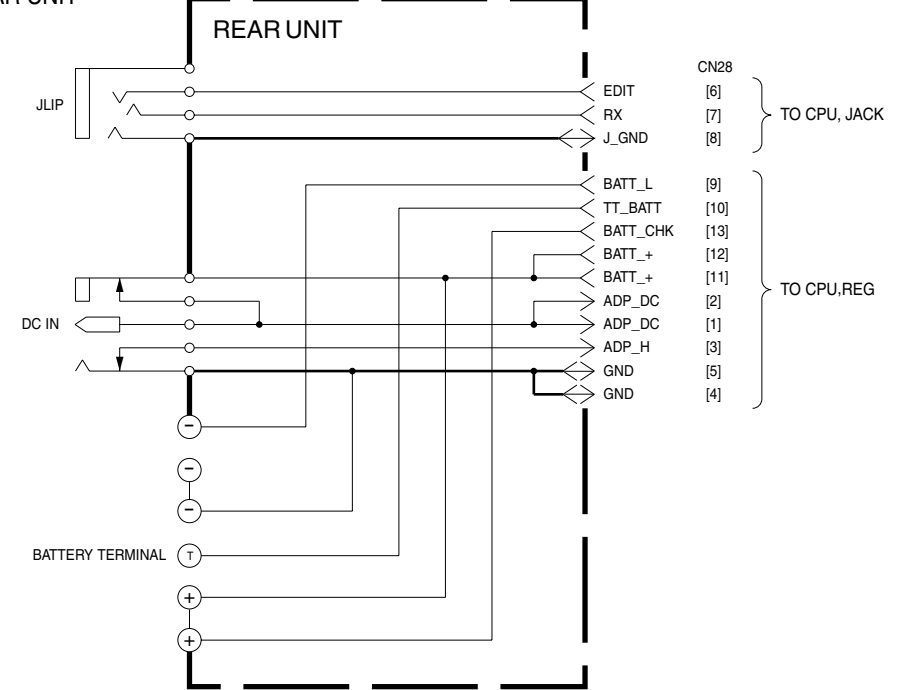

-ZOOM UNIT-

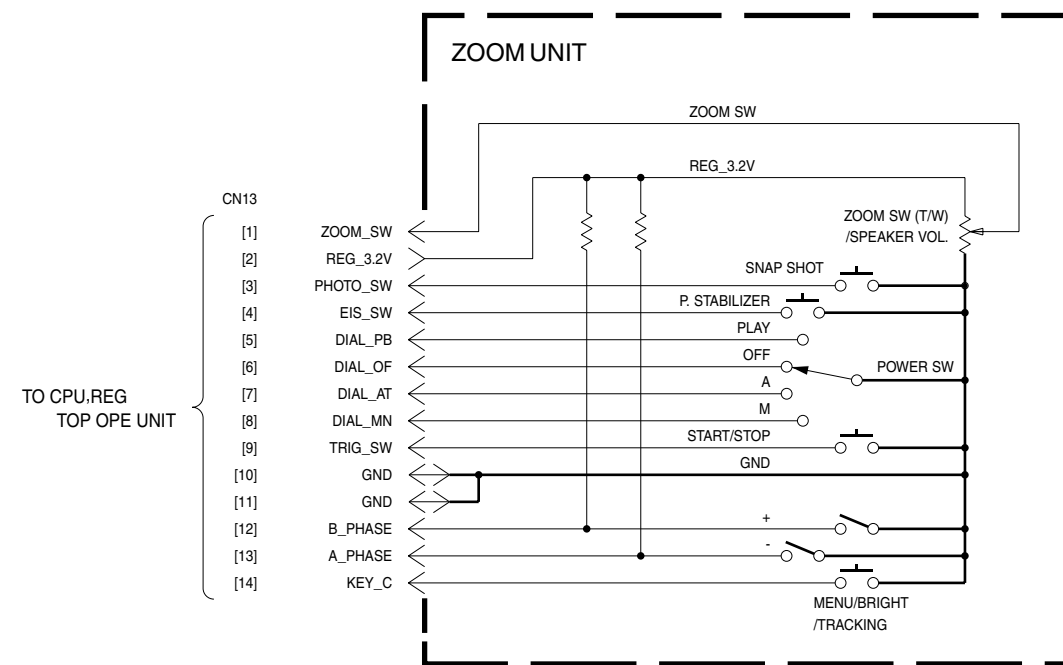

-SENSOR-

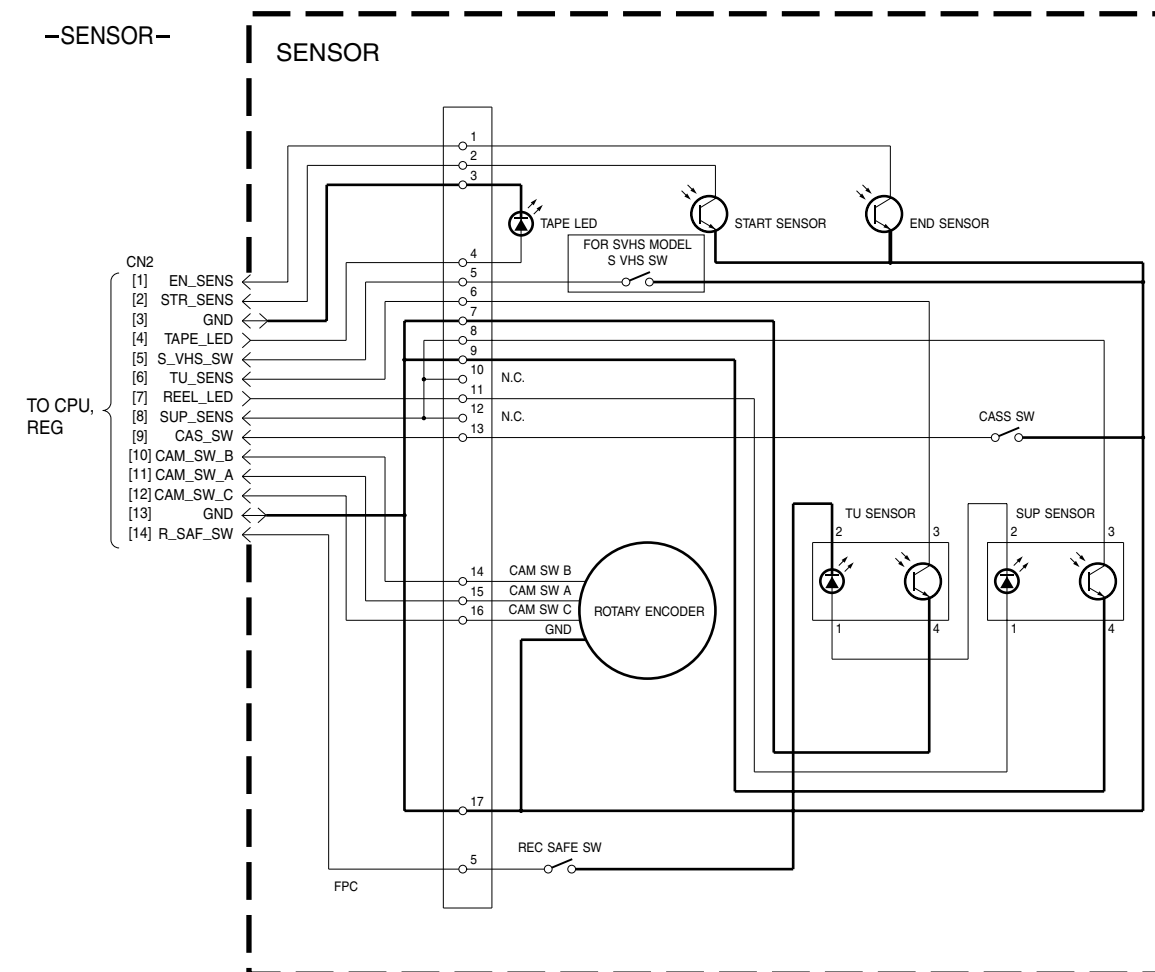

5

4

3

2

1

A

B

C

D

4-33

4-34

E

F

G

H

4.18 MAIN CIRCUIT BOARD

FOIL SIDE(B)

0 1 MAIN PWB
YB10356-01-01

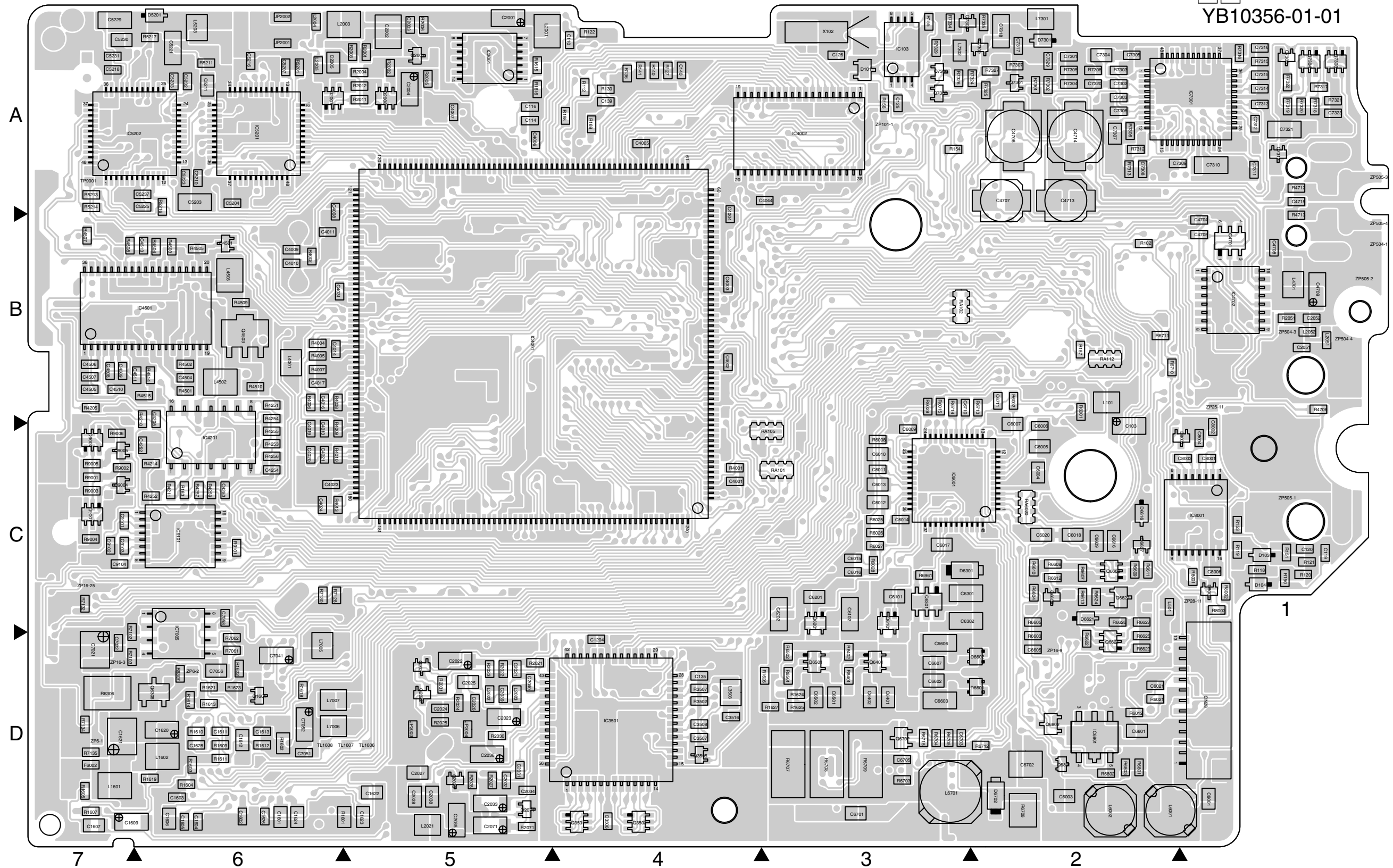



• CAUTION:
FOR CONTINUED PROTECTION AGAINST
FIRE HAZARD, REPLACE ONLY WITH SAME
TYPE AND RATED FUSE(S).

• ATTENTION:
POUR UNE PROTECTION PERMANENTE
CONTRE LES RISQUE D'INCENDE,
REPLACER LES FUSIBLES PAR UN AUTRE
DE MEME TYPE ET DE MEME TENSION.

0 1 MAIN PWB
YB10356-01-01

COMPONENT SIDE(A)

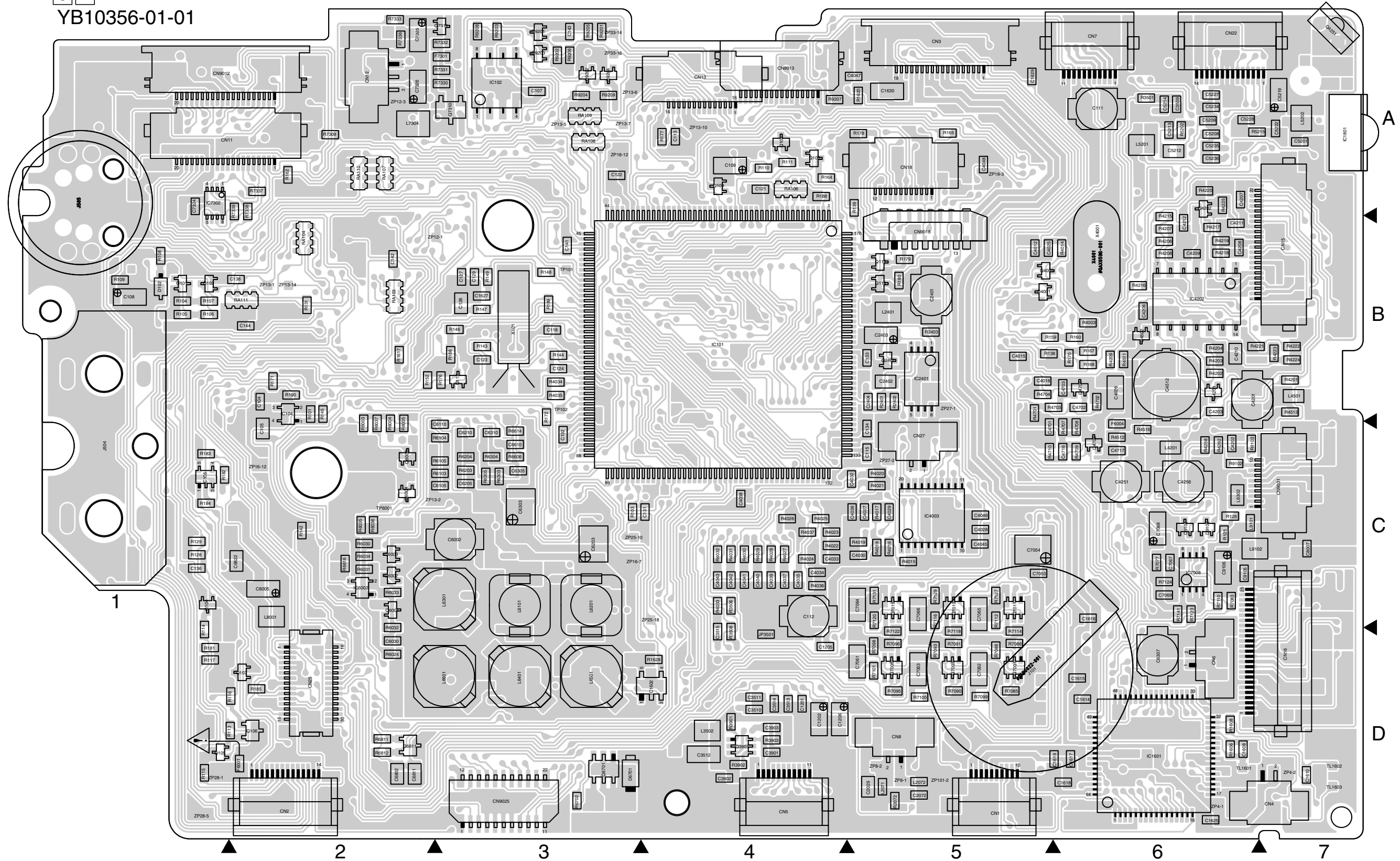

4.19 MONITOR CIRCUIT BOARD

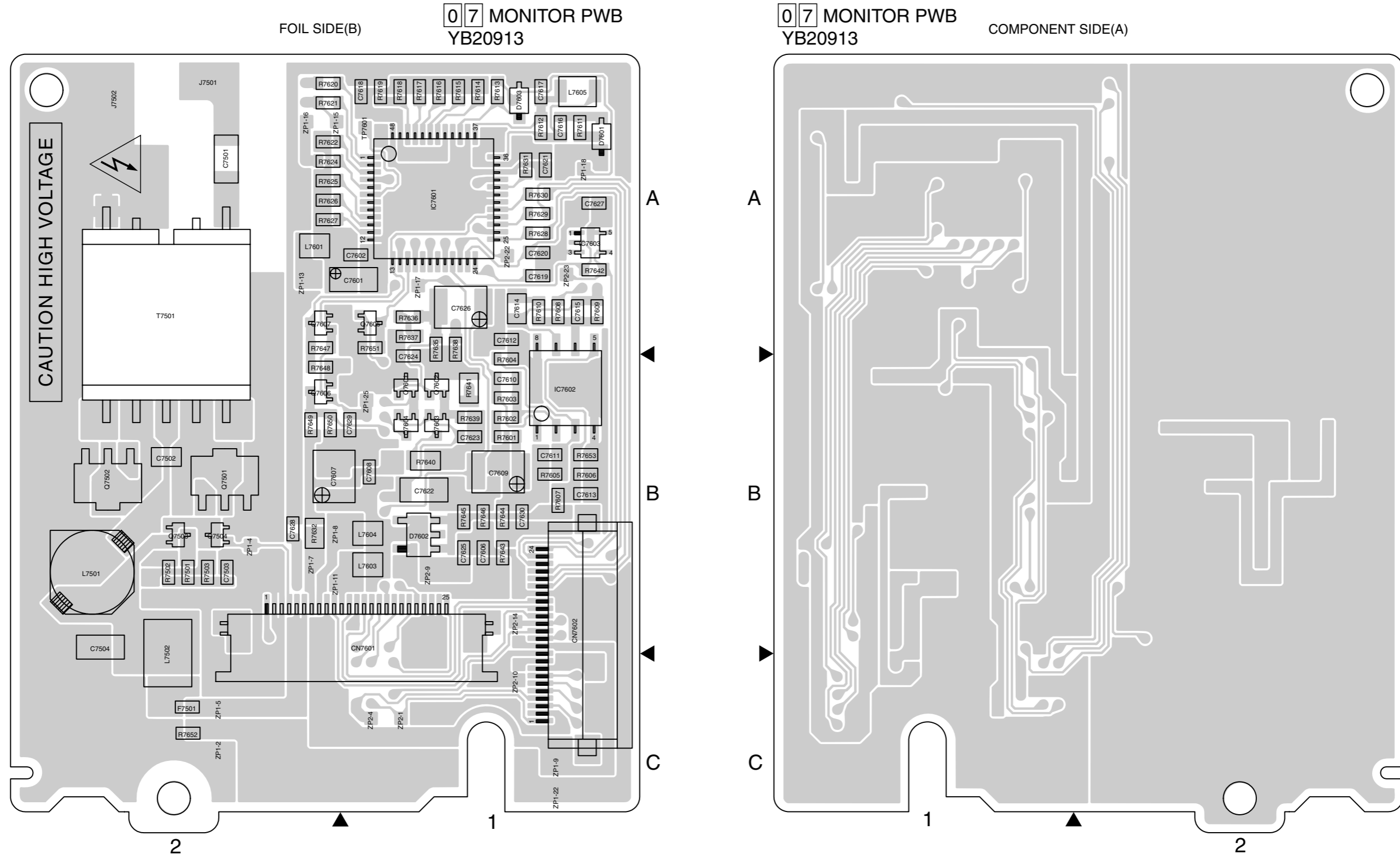

COMPONENT PARTS LOCATION GUIDE <MONITOR/YB20913>

REF.NO.	LOCATION	REF.NO.	LOCATION	REF.NO.	LOCATION	REF.NO.	LOCATION	REF.NO.	LOCATION	REF.NO.	LOCATION	REF.NO.	LOCATION	REF.NO.	LOCATION	REF.NO.	LOCATION	REF.NO.	LOCATION	REF.NO.	LOCATION	REF.NO.	LOCATION					
CAPACITOR																												
C7501	B C 2A	C7610	B C 1B	C7621	B C 1A	CONNECTOR		L7605	B C 1A	Q7606	B C 2B	R7606	B C 1B	R7617	B C 1A	R7629	B C 1A	R7642	B C 1A	R7653	B C 1B	ZP1-7	B C 2B	ZP1-18	B C 1A			
C7502	B C 2B	C7611	B C 1B	C7622	B C 1B	CN7601	B C 2B	IC7601	B C 1A	Q7607	B C 2A	R7607	B C 1B	R7618	B C 1A	R7630	B C 1A	R7643	B C 1B	TEST POINT				ZP1-8	B C 2B	ZP1-22	B C 1C	
C7503	B C 2B	C7612	B C 1A	C7623	B C 1B	CN7602	B C 1C	IC7602	B C 1B	RESISTOR		R7608	B C 1A	R7619	B C 1A	R7631	B C 1A	R7644	B C 1B	TP7601				B C 1A	ZP1-9	B C 1C	ZP1-25	B C 1C
C7504	B C 2B	C7613	B C 1B	C7624	B C 1B	DIODE		IC7603	B C 1A	Q7501	B C 2B	R7609	B C 1A	R7620	B C 2A	R7632	B C 2B	R7645	B C 1B	OTHER				ZP2-1	B C 1C	ZP2-10	B C 1C	
C7601	B C 1A	C7614	B C 1A	C7625	B C 1B	D7601	B C 1A	COIL		Q7502	B C 2B	R7610	B C 1A	R7621	B C 2A	R7635	B C 1A	R7646	B C 1B	J7501	B C 2A	ZP2-4	B C 1B	ZP2-14	B C 1B			
C7602	B C 1A	C7615	B C 1A	C7626	B C 1A	D7602	B C 1B	L7501	B C 2B	Q7503	B C 2B	R7611	B C 1A	R7622	B C 2A	R7636	B C 1A	R7647	B C 2A	J7502	B C 2A	ZP2-9	B C 1C	ZP2-22	B C 1A			
C7606	B C 1B	C7616	B C 1A	C7627	B C 1A	D7603	B C 1A	L7502	B C 2C	Q7504	B C 2B	R7612	B C 1A	R7623	B C 2A	R7637	B C 1A	R7648	B C 2B	T7501	B C 2A	ZP1-11	B C 2B	ZP2-23	B C 1A			
C7607	B C 2B	C7617	B C 1A	C7628	B C 2B	FUSE		L7601	B C 2A	Q7601	B C 1B	R7613	B C 1A	R7624	B C 2A	R7638	B C 1A	R7649	B C 2B	ZP1-2		B C 2C	ZP1-15	B C 2A				
C7608	B C 1B	C7618	B C 1A	C7629	B C 1B	F7501	B C 2C	L7603	B C 1B	Q7602	B C 1B	R7614	B C 1A	R7625	B C 2A	R7639	B C 1B	R7650	B C 2B	ZP1-4		B C 2B	ZP1-16	B C 2A				
C7609	B C 1B	C7620	B C 1A	C7630	B C 1B			L7604	B C 1B	Q7603	B C 1B	R7615	B C 1A	R7626	B C 2A	R7640	B C 1B	R7651	B C 1A	ZP1-5		B C 2C	ZP1-17	B C 1A				

4.20 CCD CIRCUIT BOARD

FOIL SIDE(B)

0 2 CCD PWB
YB10356-01-01

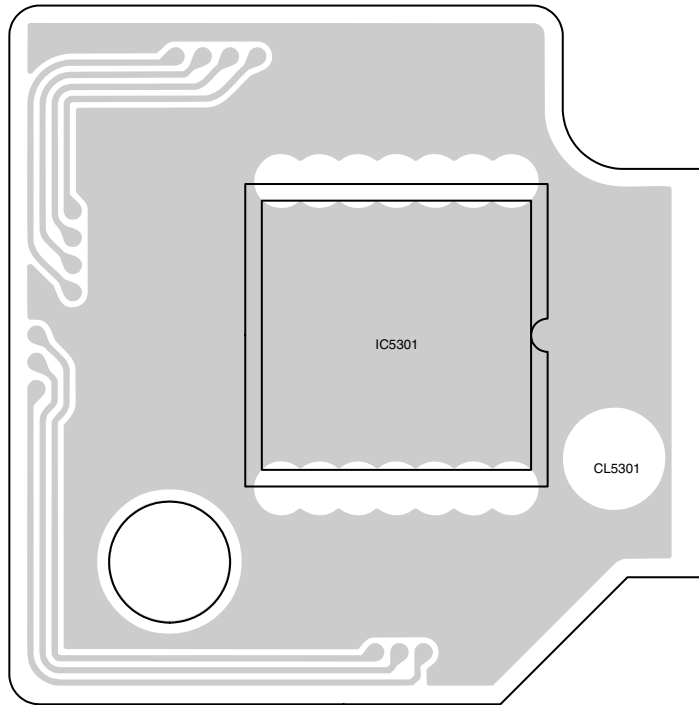

COMPONENT SIDE(A)

0 2 CCD PWB
YB10356-01-01

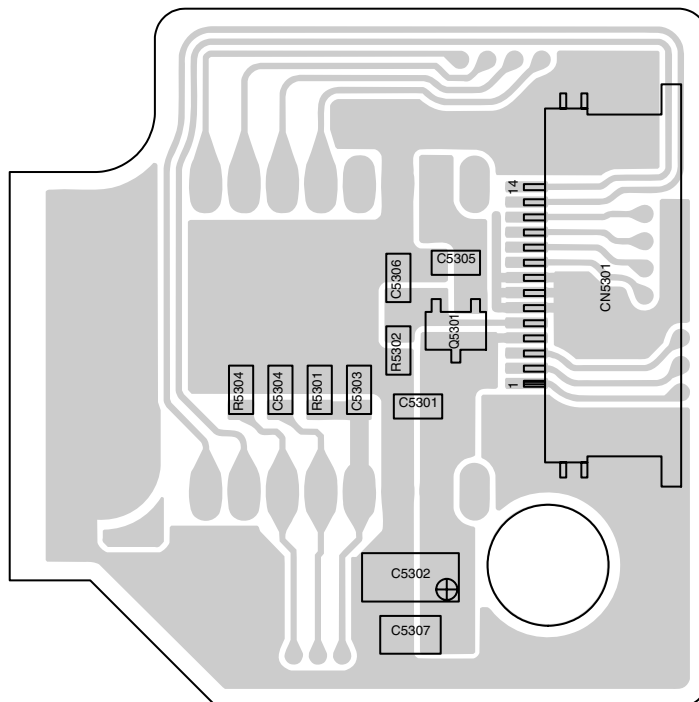

4.21 E. VF CIRCUIT BOARD

FOIL SIDE(B)

6 0 E. VF PWB

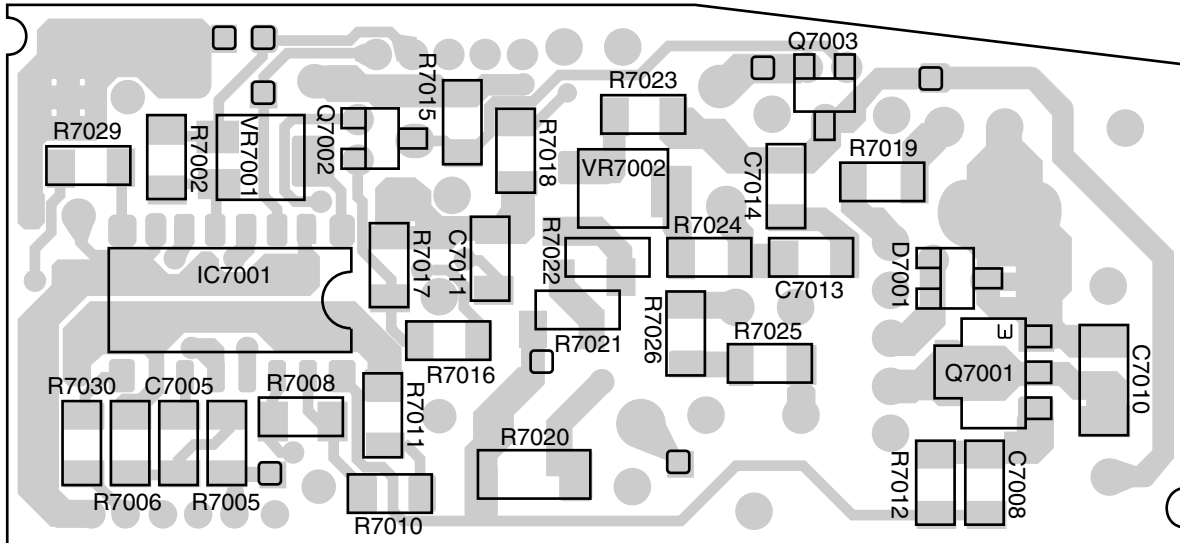

COMPONENT SIDE (A)

6 0 E. VF PWB

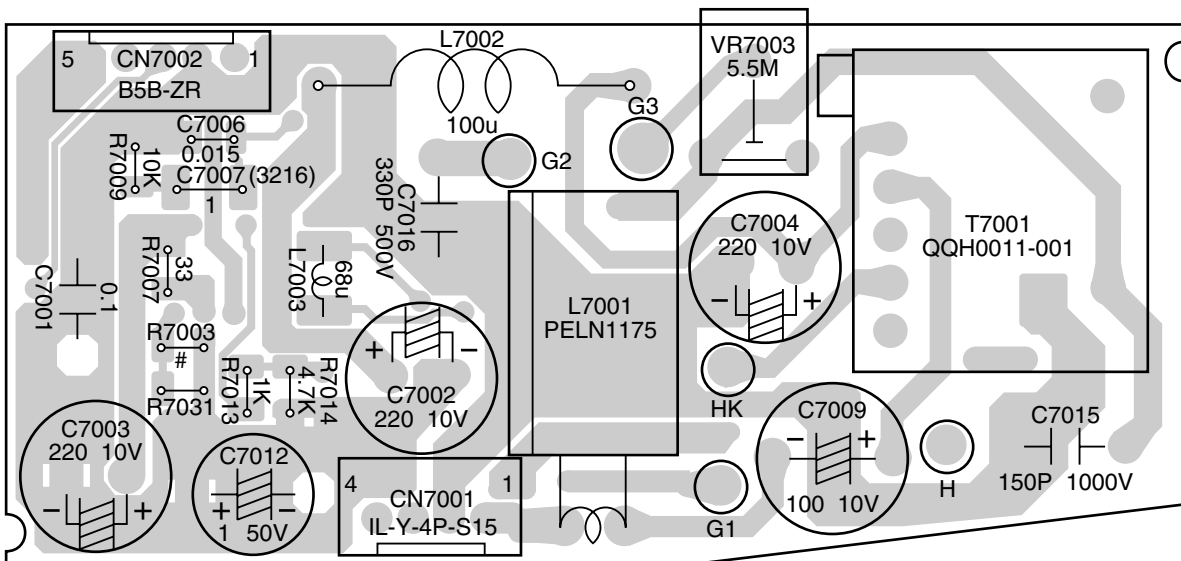

4.22 WAVEFORMS

— VTR ASP —

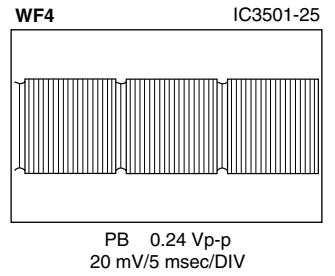
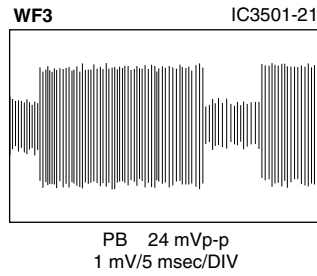
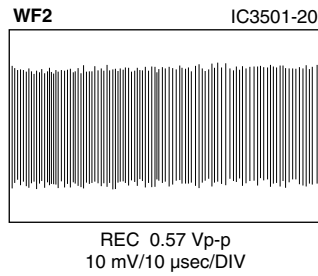
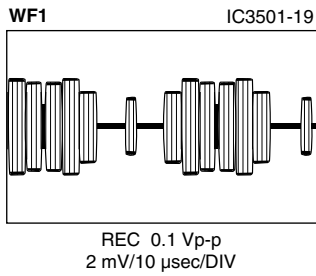

— DSP —

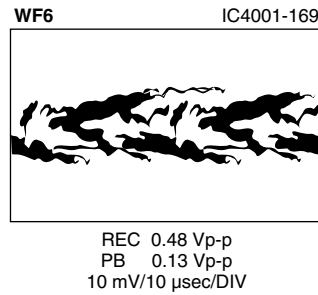
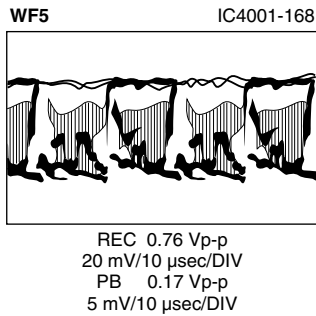
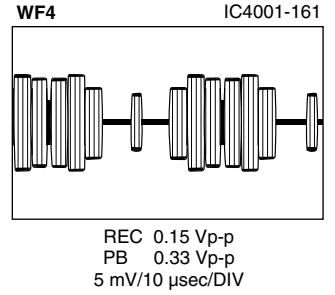
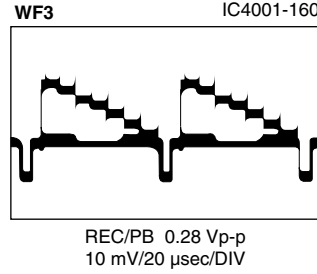
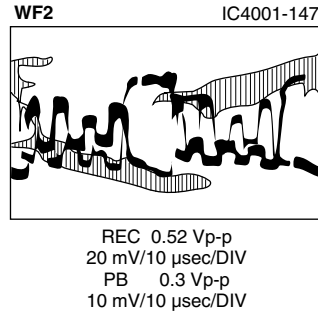
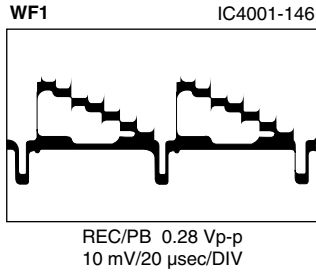

— TG/CDS —

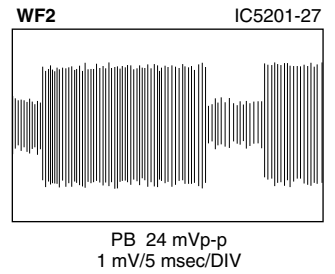
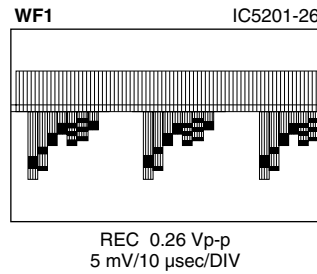

— V OUT —

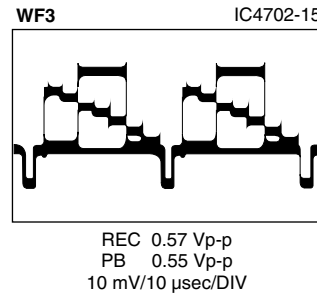
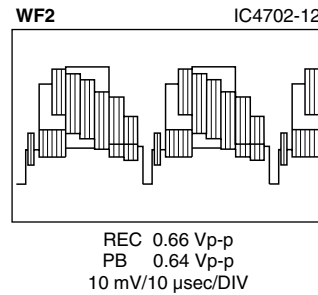
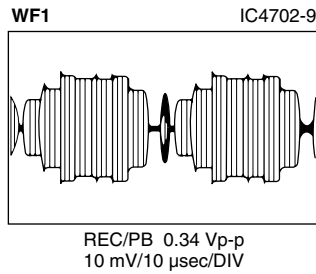

— CCD —

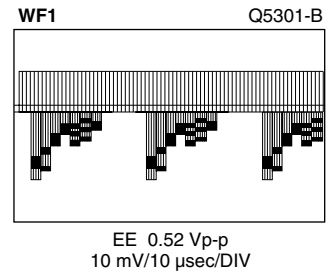

— CPU —

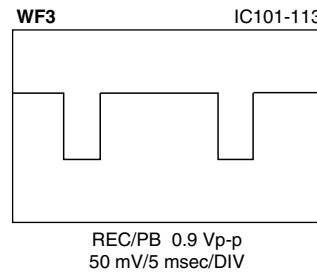
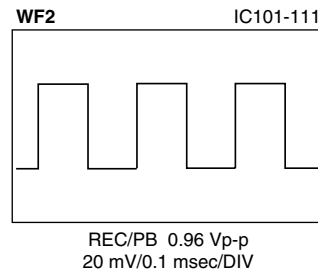
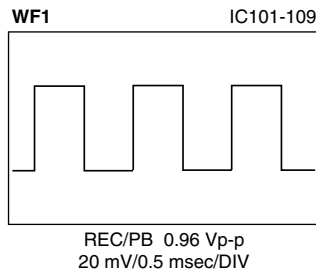

— M.MDA —

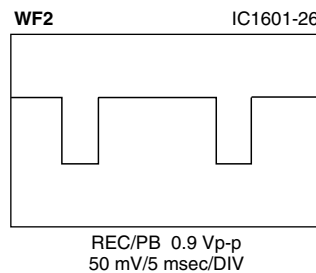
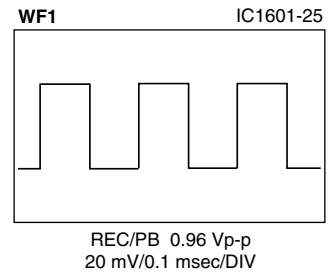

4.24 POWER SYSTEM BLOCK DIAGRAM

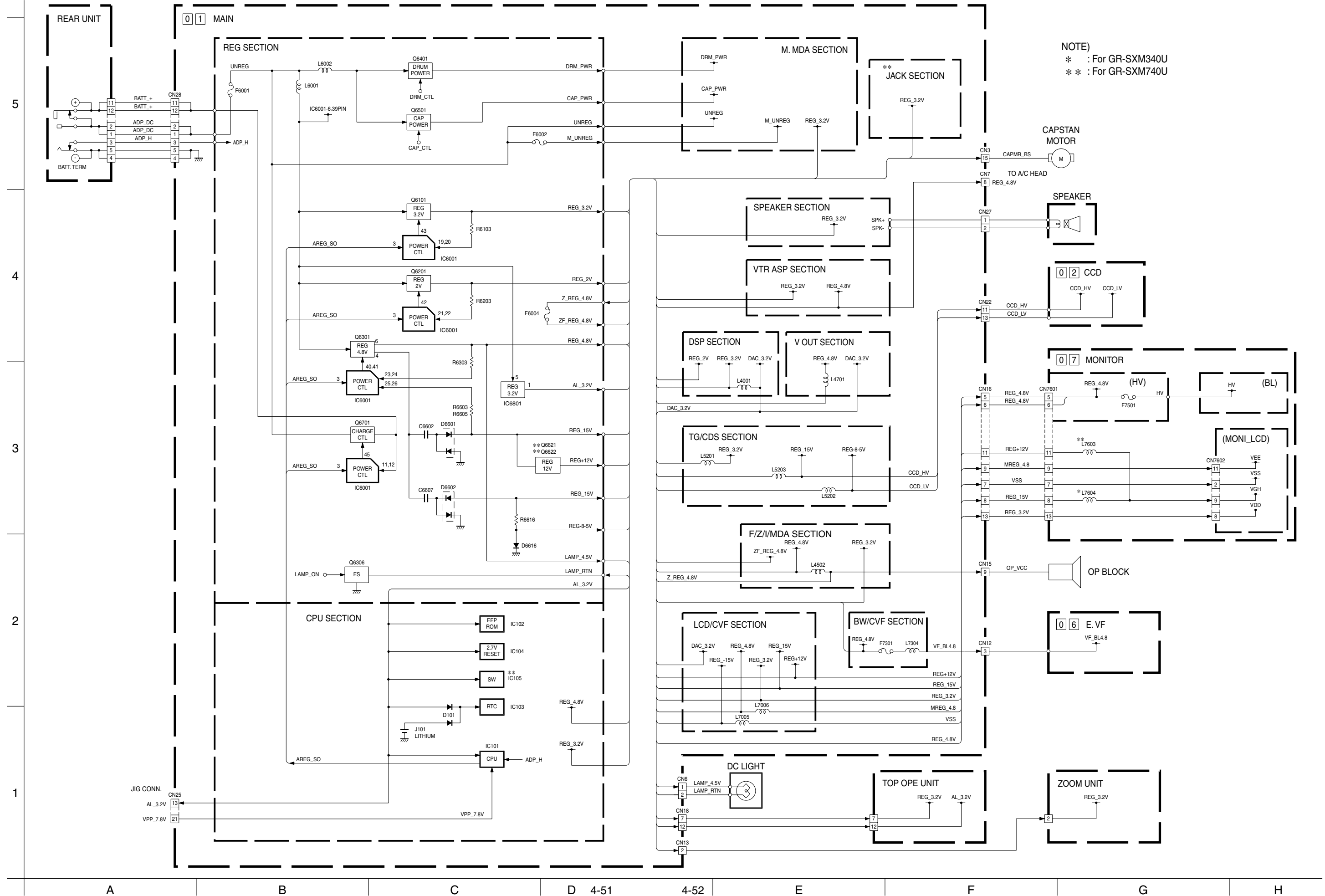

NOTE)
 * : For GR-SXM340U
 ** : For GR-SXM740U

5
4
3
2
1

A B C D 4-51 4-52 E F G H

4.25 CPU/MDA SYSTEM BLOCK DIAGRAM

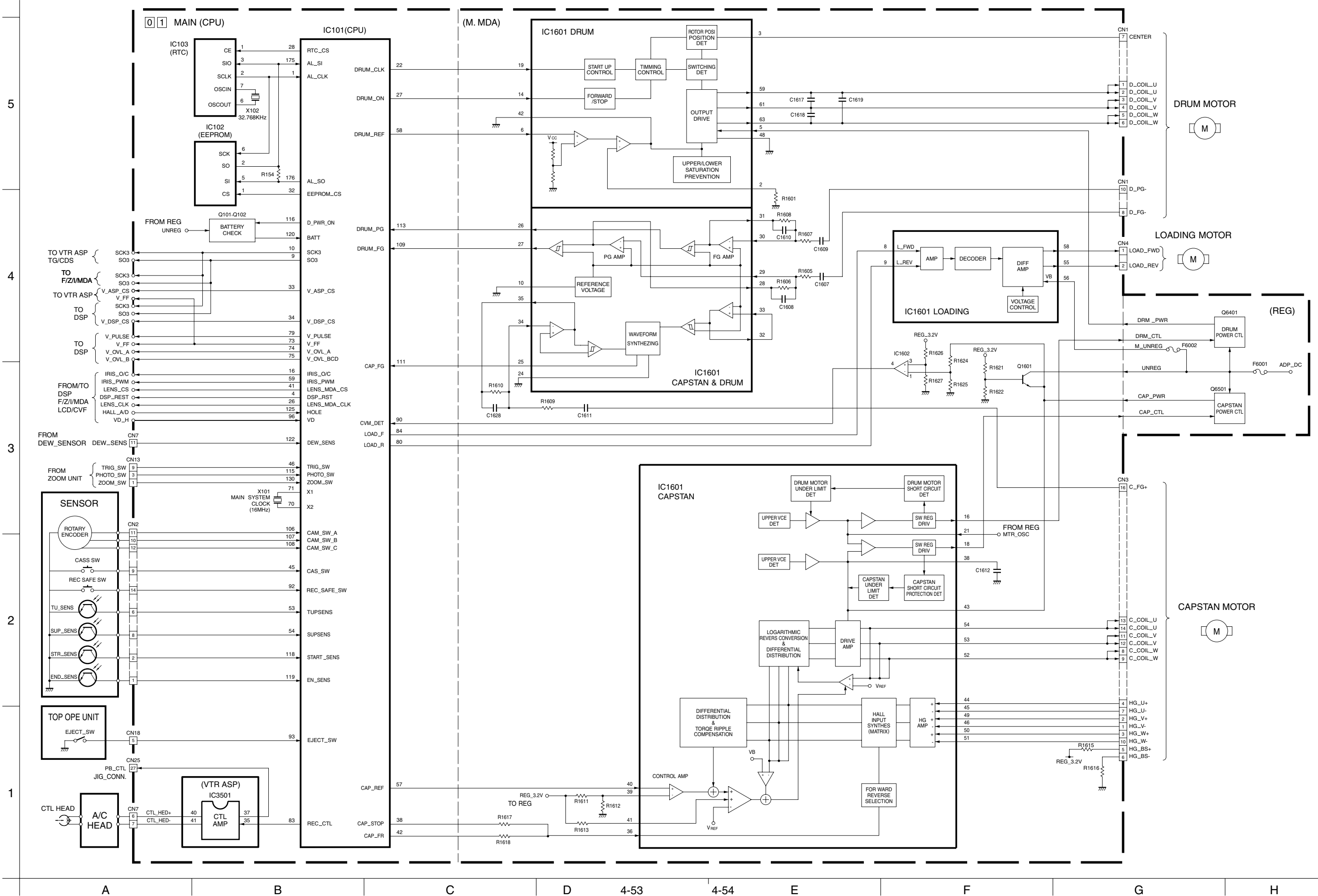

4.26 CAMERA AND Y/C SYSTEM BLOCK DIAGRAM

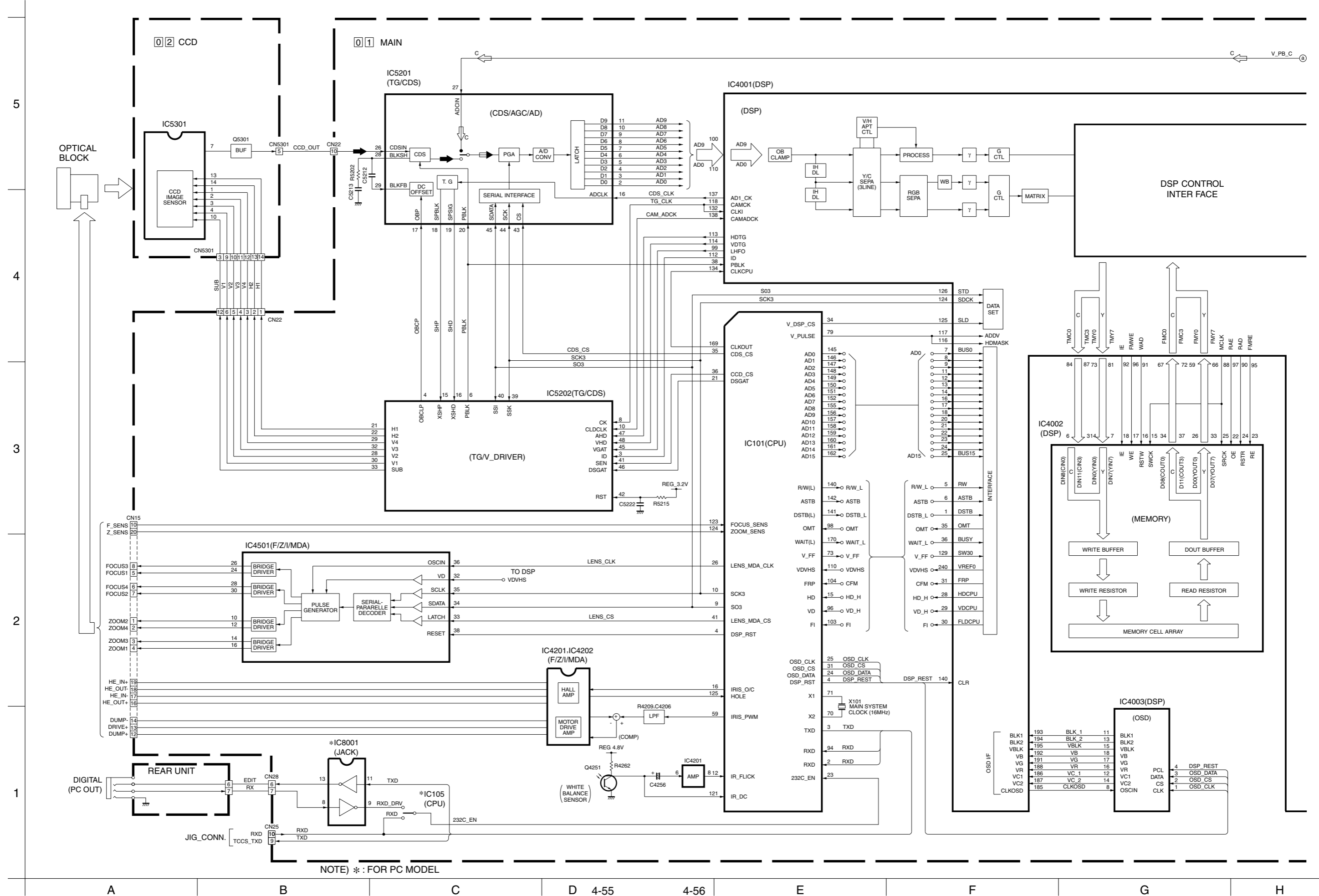

NOTE) *: FOR PC MODEL

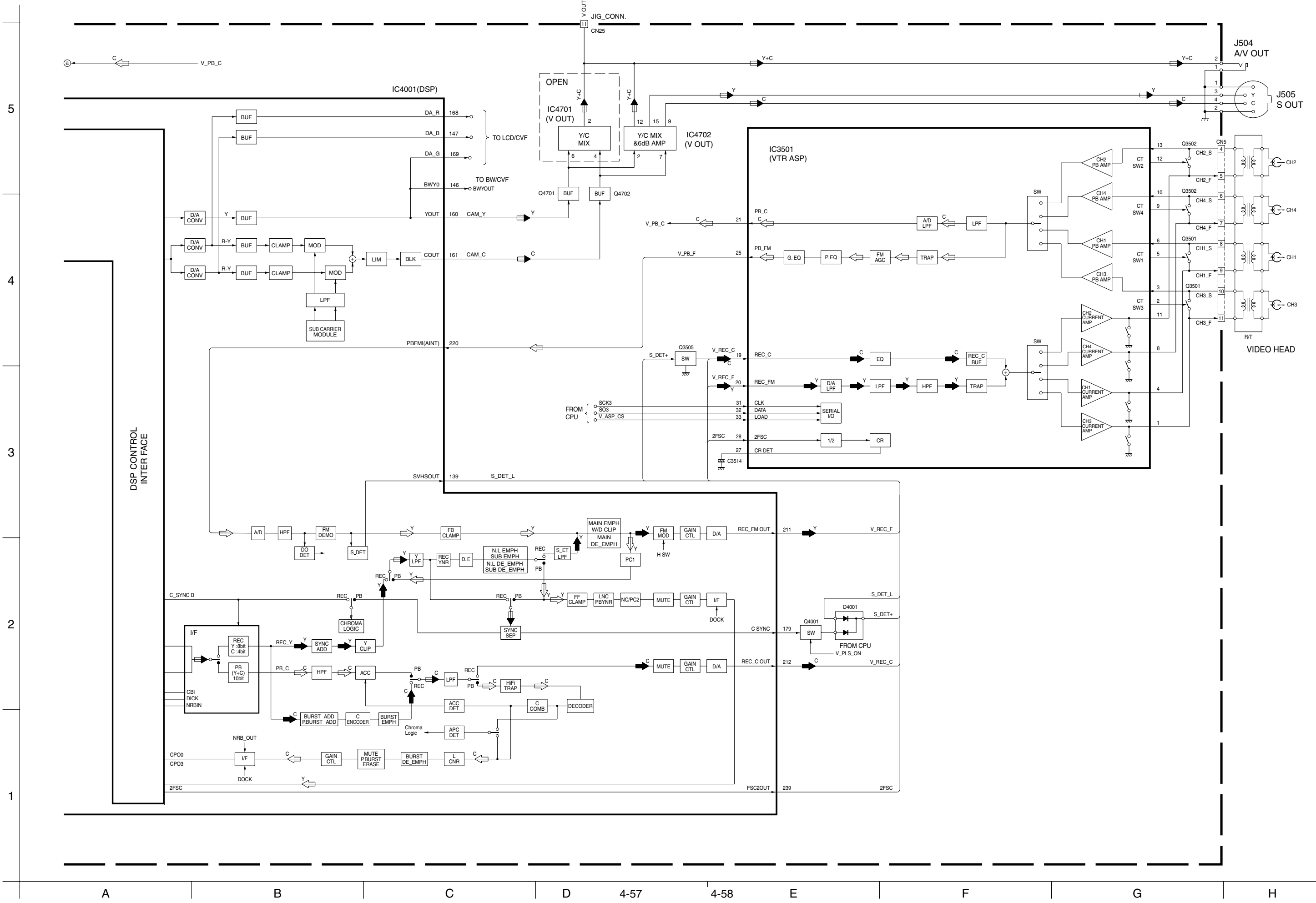

5

4

3

2

1

A

B

C

4-57

4-58

E

F

G

H

4.27 MONITOR SYSTEM BLOCK DIAGRAM

